

**BUILD YOUR OWN FLOWMETER**



**MAGX2**

**MAGB2**



**MAG E1**



**Reduced bore body**



**Agrimag**  
Series



**USC X series**

FLOW MEASUREMENT & CONTROL SPECIALIST

[www.arkon.co.uk](http://www.arkon.co.uk)

## MAGX2 Modular design suitable from most basic to most advanced applications

- ↳ The MAGX2 has an innovative modular design "Plug & Play"
- ↳ Accuracy  $\pm 0.2\%$  of actual value
- ↳ Sizes from DN20 to DN900
- ↳ Connection: DIN, ANSI, JIS, others on request
- ↳ Modbus RTU communication protocol
- ↳ External temperature and pressure input
- ↳ Wi-Fi, 3G/GPRS/GSM, TCP/IP, Bluetooth communication available
- ↳ Data-logging on a standard micro-SD card
- ↳ Leak detection feature

### MAGX2 OIML R49 and MID MI001 specifications

- ↳ Accuracy class 2
- ↳ Sizes DN25 – DN300



## MAGB2 Battery powered modular flowmeter

- ↳ Suitable for applications where the possibility of a power supply network is not available
- ↳ Accuracy is  $\pm 0.4\%$  as standard,  $\pm 0.2\%$  on request
- ↳ Sizes from DN25 to DN600
- ↳ Connections: DIN, ANSI, JIS, others on request
- ↳ Modbus RTU communication protocol
- ↳ External temperature and pressure input
- ↳ Backlit graphical display and 6 buttons to operate
- ↳ Large internal datalogger, leak detection feature
- ↳ Frequency and relay output, 4G LTE/GPRS/GSM and RS485 communication module, 4-20 mA passive output module

### MAGB2 OIML R49 and MID MI001 specifications

- ↳ Accuracy class 2
- ↳ MID sizes DN25 - DN250, OIML sizes DN25 – DN300
- ↳ Reduce bore body DN50, DN80, DN100, DN150



## MAGE1 Economic flowmeter

- ↳ Economic flowmeter with a carbon steel sensor and plastic transmitter
- ↳ DC powered flowmeter (9-35 VDC) with 4-20 mA output, RS485 communication, and internal data-logger
- ↳ Accuracy is  $\pm 0.5\%$  (0.5 to 10 m/s) of actual value
- ↳ IP67 protection
- ↳ Sizes from DN25 to DN250
- ↳ Connections: DIN, ANSI, others on request



## MAGS1 Stand-alone flowmeter

- ↳ MAGS1 is a stand-alone version of flowmeter
- ↳ Powered with 24VDC
- ↳ Sizes from DN25 to DN900
- ↳ Connection: DIN, ANSI, JIS, others on request
- ↳ Liner: Hard Rubber, PTFE, other materials on request
- ↳ Maximum nominal pressure: PN 40/300 psi
- ↳ RS485 MODBUS RTU communication



- Available in 3 sizes (25, 50 and 80mm)
- Manifold clamping flanges connections, compatible with fitting kits for DIN, BSP, NPT and other common connections
- Accuracy:  $\pm 1\%$  from 10% to 100% of full scale range
- LCD display 128x64 px graphical
- Empty pipe detection and battery saving mode
- Body material: glass filled polypropylene
- Working pressure 150psi or 10.3 bars

**Agrimag:** powered by 6 standard AA batteries, easily interchangeable

**AgrimagP:** powered by 9-35 VDC power supply, one frequency output

**AgrimagP2:** powered by 9-35 VDC power supply, 4-20 mA output, RS 485, Modbus RTU, data logger



### Parshall flumes: for open channels measuring

- Primary flow devices with a wide range of applications, for measuring open channel flow
- They can be used for flow measurement in creeks, irrigation and/or drainage channels, sewer outfalls, waste water treatment plants
- Flowrates from 0.26 to 1841 l/s
- Velocities inside Parshall flumes are high enough to prevent them from the deposition of sediments or accumulation of debris
- Minimum maintenance requirements, long life-span



### MQU ultrasonic flowmeter and MHU ultrasonic level meter: easy solution to use combined with a flume to measure open channels and level in tanks

- Innovative and high-power transmitter for every application
- Digital display, data logger for 2 months capacity, 4-20mA and pulse output and Modbus RTU via RS485 module
- Applications: Water treatment, Chemical, Food, Pharmaceutical industry, Power, Civil engineering, Agriculture
- Accuracy  $\pm 0,4\%$  of range



### USCXseries Ultrasonic clamp-on flowmeters

- Based on transit time method of measurement, suitable for various kinds of liquids
- Wide range of process outputs including RS485, Modbus RTU, Profibus and HART
- Easy setup with an intuitive installation wizard



### ARKON.TRACK: designs and supplies wireless telemetry systems for monitoring water, industrial and environmental applications at remote locations

- ARKON.TRACK is used by companies in every sector of business around the world including water companies, environmental regulators such as the Environment Agency, manufacturing and process companies and governmental organizations.
- Truly unique and allow any user to install a monitoring station anywhere in the world regardless of any constraints over power, signal or even planning issues.
- The only requirement is a GPRS coverage in order to remotely transmit data to remote servers. The flowmeters connect with the main data collection center with Dynamic IP so there is no need to purchase individual Static IP data packages for the flowmeters, which is very expensive in most countries.

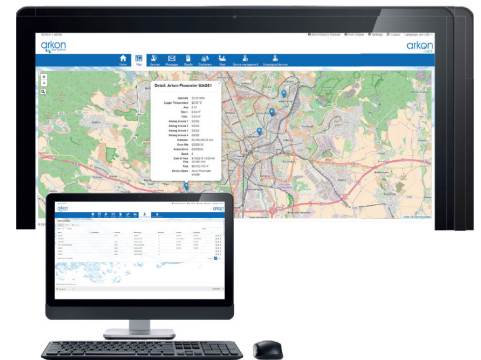

## APPLICATIONS

- 🔧 **Water & Wastewater** - distribution networks, irrigation, sludge/sewage, water treatment, leakage management, desalination, marine, checking of pumps and water wells
- 🔧 **Public utilities** - water supply system, sewage systems, wastewater, industrial water, sludge, human waste, etc.
- 🔧 **Petrochemical/chemicals** - corrosive liquids, chemicals, industrial water, waste water
- 🔧 **Paper & Pulp** - low concentration of pulp, additives, bleaches, colorants, liquor
- 🔧 **Construction** - building material slurry, sediment slurry, cement slurry, industrial water, etc.
- 🔧 **Hygienic/Sanitary** - potable water metering, food & beverages, pharmaceutical, medium, and high density fluids, blending, dosing, batching

## ADVANTAGES

The MAGX2 has an innovative modular design "Plug & Play" and it is a fit-all, flexible, low-cost flow meter all at the same time. The transmitter consists of the low-cost basic unit plus optional modules according to the end-user's requirements. Each module is in fact a small electronic board, the size of a large stamp, which can be freely installed and removed from the main board in seconds.

**YOU DO NOT PAY FOR OPTIONS YOU DO NOT WANT OR NEED.  
YOU CAN BUILD A FLOWMETER EXACTLY AS PER YOUR REQUIREMENTS.  
YOU CAN UPGRADE YOUR FLOWMETER AT ANYTIME IN THE FUTURE.**

## FEATURES

- 🔧 **Accuracy** -  $\pm 0.2\%$  (0.5 - 10 m/s) of actual value
- 🔧 **Temperature sensor** - to measure temperature of the medium
- 🔧 **Communication protocol** - Modbus RTU
- 🔧 **Self-cleaning electrodes** - electrolytic method to clean electrodes
- 🔧 **Unique design** - any upgrade, extra features inside of the flowmeter, extra protection - „Built-in design“
- 🔧 **Graphic display** - multi-language menu. Higher protection via lock-out system for buttons and 3 levels of passwords – User, Service, Factory settings.
- 🔧 **Intelligent sensor design** - digital communication allows communication between the transmitter and the sensor up to 500m. Calibration data are stored in the sensor communication module. If the transmitter is changed for whatever reason, all the calibration data will be taken from the sensor directly. No calibration download mistakes.
- 🔧 **Verification** - by field testing instrument VeriMAG2

„Built in design“ for upgrades

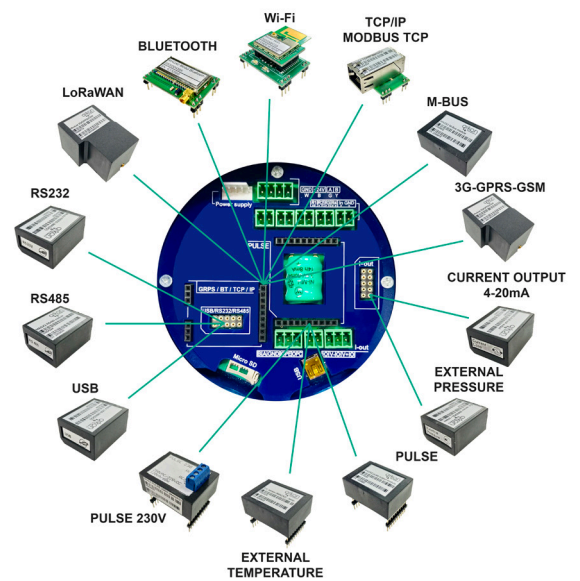

## MAGX2 POWERING OPTIONS

**PS5:** 90-250VAC or 12-36VDC - standard flowmeter power

**PS5 + external battery:** 90-250VAC or 12-36VDC + 12V battery (non-charging the external battery) - suitable for non-frequent power failures, the meter automatically switches to battery power once the main power is off. This is the inbuilt function of each PS5, the customer only adds its battery.

**PS5 + external battery backup:** An external charging battery pack is fabricated by Arkon Flow Systems. The external battery backup can power the flowmeter for 20 hours then the battery backup needs to be charged for 8 hours. It is useful for application that has frequent power outage.

## MAGX2 BASIC WORKING VERSION CONSISTS OF:

TRANSMITTER



POWER SUPPLY



SENSOR COMMUNICATION MODULE  
(calibration data are stored here)



**Sensor** (all sensors include 4 electrodes, self-cleaning electrodes system and empty pipe detection)



That is basic configuration for a **MAGX2** working unit. It only allows communication with the flowmeter via keypad and does not include any output or data-logging function. Flowrate and totalizer can be checked on the display only.

Arkon offers a wide range of optional modules which are not necessary for a working unit but can be added to the basic configuration to add extra features.

### Currently, the following optional modules are available:



RS485



RS232



USB

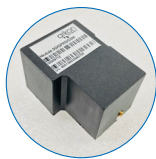

3G/GPRS/GSM



WI-FI

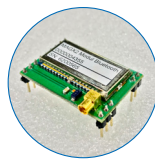

Bluetooth



TCP/IP  
MODBUS TCP



M-Bus

Arkon offers 4-20mA output and two different types of pulse output. Both options can be used separately or combined. Out of the two pulse options only one pulse option could be used or installed at any given time.



Current output  
4-20mA



Pulse  
output



Pulse  
230

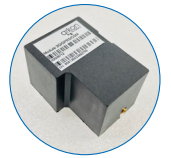

LoRaWAN

Data-logging option  
MAGX2 motherboard includes a real time clock. For data-logging you just need a standard micro SD memory card. We can supply it for you or you can buy it yourself locally.

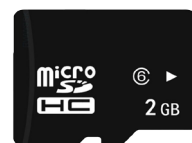

## RS232 COMMUNICATION MODULE

Standard for serial communication data transmission, commonly used for PLC and old PC.

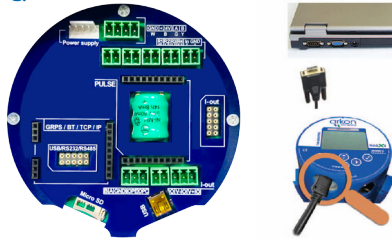

## USB COMMUNICATION MODULE

A standard for computer communication.

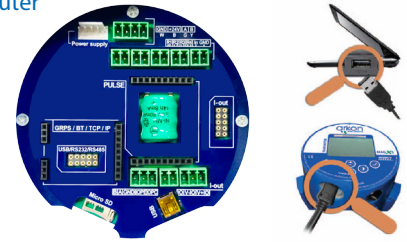

## RS485 COMMUNICATION MODULE

A standard for industrial communication, up to 32 devices on one line without repeaters. Termination resistor may be needed.

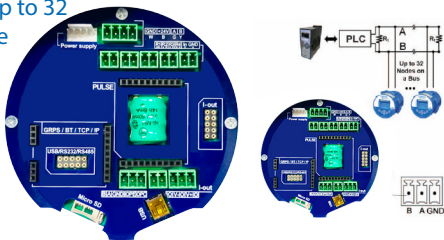

## BLUETOOTH COMMUNICATION MODULE

Cables are not required to check your flowmeter within a 200 m range.

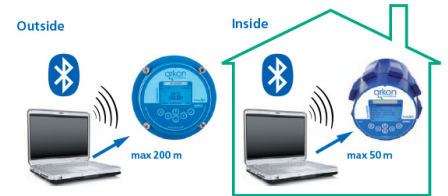

## TCP/IP COMMUNICATION MODULE

Ethernet communication with flowmeter within your local network or even through internet. A MODBUS RTU over TCP/IP (serial) protocol is used.



## 3G/GPRS/GSM COMMUNICATION MODULE

Wireless communication system. The measurement can be evaluated from anywhere in the world.



## WI-FI COMMUNICATION MODULE

Easy communication between flowmeter, PC or PLC system with no data cables needed. A MODBUS RTU over TCP/IP (serial) protocol is used.

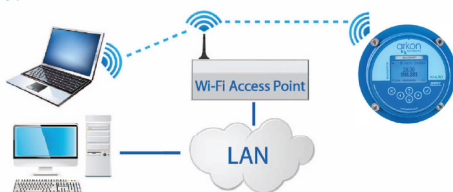

## LoRaWAN COMMUNICATION MODULE

A true IOT module for radio communication in LPWA network. The MAGX2 sends the flow rate and the total volume by LoRaWAN network. Specific interval of sending data is fixed to 30minutes. Range up to 15000mts (Line of sight).



## EXTERNAL SENSORS

External pressure and temperature sensors supplement measurement of additional parameters.



## M-BUS COMMUNICATION MODULE

Standard for the remote reading of flow meter. The M-Bus interface is made for communication on two wires, making it cost-effective. Finding its use in HVAC systems of modern buildings.





## TRANSMITTER SPECIFICATIONS

Measurable media	Conductive fluids
Min. media electrical conductivity	≥5µS/cm or ≥20µS/cm for demineralized water
Flow range	0.1 to 10 m/s
Displayed values	Actual flow (m³/h l/s, l/m, US.gal/min, UK.gal/min), volume (m3, l, US.gal, UK.gal), positive, negative, total volume and auxiliary (clearable) volume, velocity[m/s], sensor temperature
Accuracy	±0.2% (0.5 - 10 m/s) of actual value
Power supply	12-36 VDC, 90-250 VAC, including battery back-up option
Power consumption	option Max. 15VA
Communication protocol	Modbus RTU can be used with all the communication modules i.e. RS232, RS485, USB, BLUETOOTH, TCP/IP, Wi-Fi
Flow direction	Bi-directional measurement
Ambient temperature	- 20°C to 60°C (-4°F to 140°F)
Display	LCD 128 x 64 px graphical, contrast setup
Controls	6 buttons + communication modules
Low flow cut-off	OFF, 0.5%, 1%, 2%, 5%, 10% of Flow Qn
Adjustable filter constant	1 - 120 samples; default value is 15 samples
Max. electronics weight (including housing)	2 kg
Housing material	Aluminium (powder coated)
Housing dimensions	Ø 143 mm
Cable terminal	3+1xM20x1.5 IP68 cable gland
Electronics protection	IP68
Other features	Auto-diagnostics • Multi-language options (English, Spanish, Russian, Ukrainian, Turkish, other languages possible) • Indicative temperature measurement up to 150°C • Test of excitation coils • Empty pipe detection Zero flow adjustment • Flow simulator • Verification tool available
Excitation frequency	3.125 Hz or 6.25 Hz
Real time	Clock function for data-logging
Analogue outputs	Optionals: Current 4-20 mA, Pulse, Pulse 230
Analogue inputs	Optionals: Temperature, Pressure
Digital outputs (communication)	Optionals: USB, RS232, RS485, BLUETOOTH, TCP/IP, 3G/GPRS/GSM, Wi-Fi, LoRaWAN, M-Bus, MODBUS TCP
Data logger	Micro SD card
Certification	EMC, ES, PED, IP68, WRAS, OIML R49, MID



## SENSOR SPECIFICATIONS

Connection types	DIN, ANSI, JIS flanges. Other types on request
Flange	Carbon steel as standard. Dimensions according to DIN EN 1092-1, ASME B 16.5, JIS B 2239
Nominal size	25-900 mm (3/4" - 36")
Maximum nominal pressure	PN 40/300 psi
Max.media temperature	70°C (158°F) for Hard Rubber liner, 130°C (266°F) for PTFE liner in remote version
Ambient temperature	- 20 to 60°C (-4 to 140°F)
Sensor protection	Remote IP68 (NEMA 6)
Liner	Hard Rubber, PTFE, other material on request, WRAS approved material available for sizes up to DN600
Electrodes	Stainless steel 1.4571 (316Ti), Hastelloy C-276, other on request
Measuring tube	Stainless steel 1.4301 dimensions according to EN 10027-2
Outer casing	Carbon steel (1.0036) as standard
External coating	Lacquered finish (anticorrosive)
Accessories options	Earthing rings for plastic and lined pipes
Coils resistance	100 Ω
Other features	Earthing through 3 <sup>rd</sup> and 4 <sup>th</sup> electrode Self-cleaning electrodes

## MAGX2 OIML R49 AND MID MI001 SPECIFICATIONS

Special version of MAGX2 flowmeter – check order codes
Accuracy class 2 (+-5% Q1-Q2, +-2% Q2-Q4), R up to 400
Flow profile class USD3, Temperature class T50
Environmental class B, E2; Pressure loss ΔP 10
Maximal applicable pressure class MAP10
Compact and remote configuration, RS485 and frequency output
PTFE, Hard Rubber and Soft Rubber liners
Sizes DN25 – DN300

## TECHNICAL DRAWING DATA-SHEET IP68 TRANSMITTER

### DIN

DN	ØD	D1	CxØd	L	H-compact	H-remote
	[mm]	[mm]	[mm]	[mm]	[mm]	[mm]
20	105	75	4x14	200	305	210
25	115	85	4x14	200	310	215
32	140	100	4x18	200	330	235
40	150	110	4x18	200	340	240
50	165	125	4x18	200	355	255
65	185	145	8x18	200	375	275
80	200	160	8x18	200	390	295
100	220	180	8x18	250	410	315
125	250	210	8x18	250	445	345
150	285	240	8x22	300	480	385
200	340	295	12x22	350	540	440
250	405	355	12x26	400	605	505
300	460	410	12x26	500	645	545
350	520	470	16x26	500	715	615
400	580	525	16x30	600	763	670
450	640	585	20x30	600	805	705
500	715	650	20x33	600	860	765
600	840	770	20x36	600	970	875
700	895	840	24x30	700	1085	985
800	1015	950	24x33	800	1195	1095

### ANSI

DN	ØD	D1	CxØd	L	H-compact	H-remote
	[mm]	[mm]	[mm]	[mm]	[mm]	[mm]
3/4"	98.6	69.9	4x15.7	200	305	205
1"	108	79.2	4x15.7	200	310	210
1.1/4"	117.3	88.9	4x15.7	200	320	220
1.1/2"	127	98.6	4x15.7	200	325	230
2"	152.4	120.7	4x19.1	200	345	250
2.1/2"	177.8	139.7	4x19.1	2200	370	270
3"	190.5	152.4	4x19.1	200	385	290
4"	228.6	190.5	8x19.1	250	415	320
5"	254	215.9	8x22.4	250	445	345
6"	279.4	241.3	8x22.4	300	480	380
8"	342.9	298.5	8x22.4	350	540	440
10"	406.4	362	12x25.4	400	610	510
12"	482.6	431.8	12x25.4	500	665	565
14"	533.4	476.3	12x28.4	500	725	630
16"	596.9	539.8	16x28.4	600	780	685
18"	635	557.9	16x31.8	600	815	715
20"	698.5	635	20x31.8	600	875	780
24"	812.8	749.3	20x35.1	600	990	890
A28	927	863.6	28x34.9	700	1100	1000
A32	1060.5	977.9	28x41.3	800	1215	1120

### Compact version:

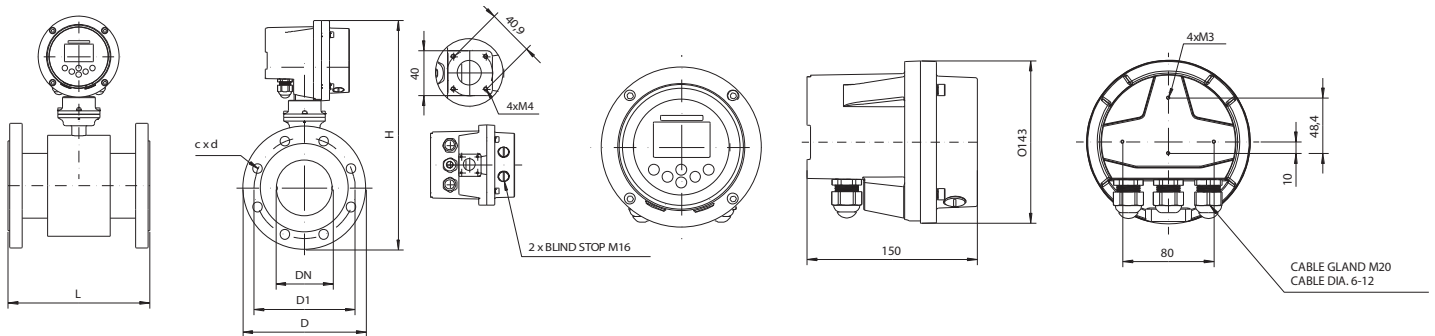

### Remote version:

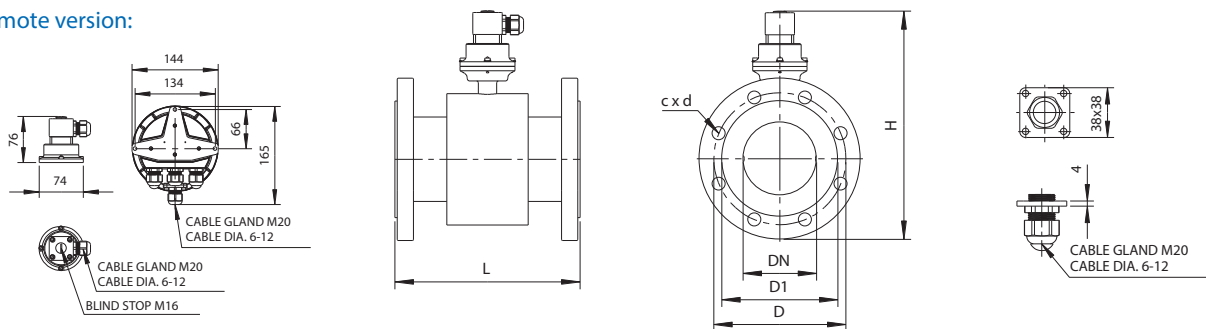

Tolerance of built-in length:  
 DN 10 – DN 150 L ± 5 mm  
 DN 200 – DN 1000 L ± 10 mm

Standard pressure:  
 DN 20 – DN 50 PN 40 / 150 lbs.  
 DN 65 – DN 150 PN 16 / 150 lbs.  
 DN 200 – DN 800 PN 10 / 150 lbs.

Max. electronics weight (including housing)	2 kg
Housing material	Aluminium + powder coating
Housing dimensions	Ø 143mm
Cable terminal	3+1xM20x1.5 IP68 cable gland
Electronics protection	IP68 / NEMA 6

## APPLICATIONS

- Water & Wastewater - distribution networks, irrigation, sludge/sewage, water treatment, desalination, marine, checking of pumps and water wells
- Petrochemical/chemicals/sanitary - corrosive liquids, dosing of additives, chemicals, industrial water, wastewater, potable water metering, food, pharmaceutical industry, medium, and high-density fluids, blending
- Paper & Pulp - additives, bleaches, colorants, liquor

## ADVANTAGES

Possibility to install a reliable flowmeter virtually anywhere without sacrificing accuracy or performance. Top accuracy is 0,4 % (0,2 % on request) of the actual value. No mains power is required. It is an ideal flow measurement device for water and wastewater systems located at remote sites.

## FEATURES

- Battery-powered electromagnetic flowmeter
- Accuracy is  $\pm 0,4\%$  as standard,  $\pm 0,2\%$  on request
- Empty pipe detection automatically turns off the excitation to prolong battery life
- Graphical display 128\*64 px and keypad for simple operation
- Modbus RTU communication protocol via USB and optional RS485
- Isolated binary outputs - relay and frequency output
- External temperature and external pressure sensor available
- Easy access to data on-site
- Standard USB interface for configuration and data collection using MAGB2 software
- Full keypad for simple operation, setup and instant access to information about totalizers
- Adjustable intelligent filter
- Maintenance-free
- Two built-in earthing electrodes
- No moving parts in the measuring tube



### ADDITIONAL MODULES:

4G LTE/GPRS/GMS	communication module
4-20 mA	passive output
RS485	communication module
LoRaWAN	communication module



## POWER SUPPLY

- MAGB2 is designed as a battery operated flowmeter, for some application however it is possible to use mains power supply. Meter then can work from 90-250VAC or 12-36VDC.
- MAGB2 is in this setup measuring with maximal excitation frequency.

## BATTERY

- Battery life up to 10 years
- 5x3.6 V battery pack placed inside the transmitter
- External battery pack for battery life up to 15 years
- Battery conservation when the pipe is empty



## EXTERNAL INPUT OPTIONS

In the case of complex measurement points where not only flow measurement is needed, MAGB2 offers the possibility of pressure and temperature external sensors connection. Those sensors are installed in the pipework and wired directly to MAGB2. In MAGB2 the temperature and/or pressure value is read and saved in a datalogger. Arkon Flow Systems offers those special low-power external sensors as spare parts.

## TRANSMITTER SPECIFICATIONS

Measurable media	Conductive fluids
Min. media electrical conductivity	$\geq 5\mu\text{S/cm}$ or $\geq 20\mu\text{S/cm}$ for demineralized water
Flow range	0.1 to 10 m/s
Displayed values	Actual flow, volume, positive, negative, total volume and auxiliary volume
Accuracy	$\pm 0,4\%$ of actual value
Power supply	Internal lithium battery – battery life up to 10 years
Communication	Modbus RTU
Flow direction	Bi-directional measurement
Ambient temperature	- 20 to 60°C
Display	Graphical, contrast setup, sleep mode, backlight
Control	6 touch buttons + communication modules
Electronics weight	2 kg
Housing material	Aluminum (powder coated)
Housing dimensions	$\varnothing 143$ mm
Cable terminals	3+1xM20x1.5 IP68 cable gland
Electronics protection	IP68
Other features	Test of excitation coils • Empty pipe detection • Zero flow adjustment Flow simulator • IrDa + IR remote control on request
Inputs	External temperature (optional) • External pressure (optional)
Inbuilt outputs	Frequency • Pulse • USB
Frequency output	Configurable to be flow dependant • Galvanically isolated open drain
Pulse output	One latching relay output configurable to an error detection or flow dependant • Status or volumetric information Galvanically isolated dry contact
Optional Modules	4G LTE/GPRS/GSM, RS485, 4-20mA, LoRa
4G LTE/GPRS/GSM	Sending flow and totalizer
Data logger	Internal, 119680 records



## SENSOR SPECIFICATIONS

Connection types	DIN, ANSI, Other types on request
Flange	Steel 1.0036 or higher
Nominal size	25-600 mm, other sizes on request
Maximum nominal pressure	PN 40/300 psi
Ambient temperature	- 20 to 60°C
Sensor	IP68
Liner	Hard Rubber, PTFE, Hygienic Rubber, other material on request
Electrodes	Stainless steel 1.4571 (316Ti), Hastelloy C-276, other on request
Measuring tube	Stainless steel 1.4301
Outer casing	Carbon steel (1.0036) as standard
External coating	Lacquered finish (anticorrosive)
Accessories options	Earthing rings for plastic and lined pipes
Coils resistance	100 $\Omega$
Other features	Earthing through 3 <sup>rd</sup> and 4 <sup>th</sup> electrodes



## MAGB2 OIML R49 AND MID MI001 SPECIFICATIONS

Special version of MAGB2 flowmeter – check order codes
Accuracy class 2 (+-5% Q1-Q2, +-2% Q2-Q4. R up to 250
Flow profile class U0D0, Temperature class T50
Environmental class B, E2; Pressure loss $\Delta P$ 16
Maximal applicable pressure class MAP16
Compact and remote configuration, RS485 and frequency output
PTFE, Hard Rubber and Soft Rubber liners
MID sizes DN25 - DN250, OIML sizes DN25 – DN300



## TECHNICAL DRAWING DATA-SHEET IP68 TRANSMITTER

### DIN

DN	ØD	D1	CxØd	L	H-compact	H-remote
	[mm]	[mm]	[mm]	[mm]	[mm]	[mm]
25	115	85	4x14	200	275	178
32	140	100	4x18	200	293	196
40	150	110	4x18	200	302	205
50	165	125	4x18	200	316	219
65	185	145	8x18	200	336	239
80	200	160	8x18	200	354	257
100	220	180	8x18	250	374	277
125	250	210	8x18	250	407	310
150	285	240	8x22	300	440	343
200	340	295	12x22	350	496	399
250	405	355	12x26	400	566	469
300	460	410	12x26	500	615	518
350	520	470	16x26	500	683	586
400	580	525	16x30	600	686	640
450	640	585	20x30	600	780	685
500	715	650	20x33	600	847	750
600	840	770	20x36	600	964	870

### ANSI

DN	ØD	D1	CxØd	L	H-compact	H-remote
	[mm]	[mm]	[mm]	[mm]	[mm]	[mm]
1"	108	79.2	4x15.7	200	271	174
1.1/4"	117.3	88.9	4x15.7	200	282	185
1.1/2"	127	98.6	4x15.7	200	290	193
2"	152.4	120.7	4x19.1	200	309	212
2.1/2"	177.8	139.7	4x19.1	200	332	235
3"	190.5	152.4	4x19.1	200	349	252
4"	228.6	190.5	8x19.1	250	378	281
5"	254	215.9	8x22.4	250	409	312
6"	279.4	241.3	8x22.4	300	437	340
8"	342.9	298.5	8x22.4	350	497	400
10"	406.4	362	12x25.4	400	566	469
12"	482.6	431.8	12x25.4	500	626	529
14"	533.4	476.3	12x28.4	500	690	593
A16	596.9	539.8	16x28.4	600	695	649
A18	635	577.9	16x31.8	600	778	682
A20	698.5	635	20x31.8	600	839	742
A24	812.8	749.3	20x35.1	600	951	857

### Compact version:

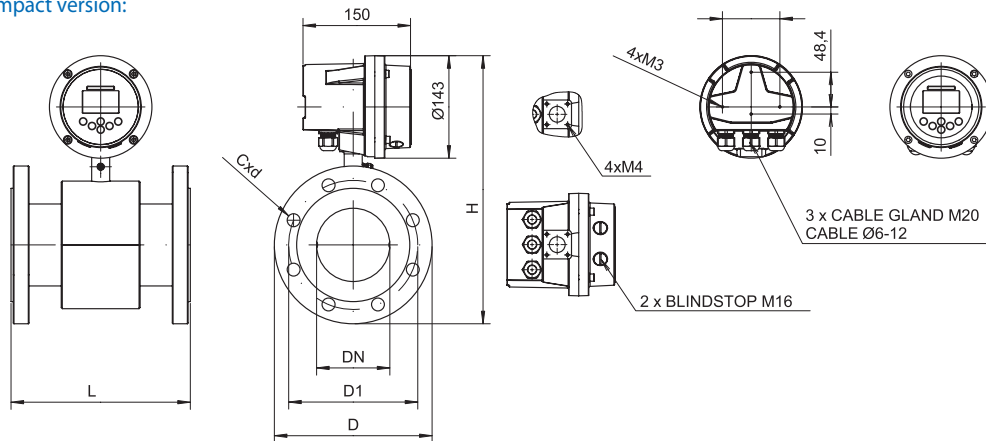

### Remote version:

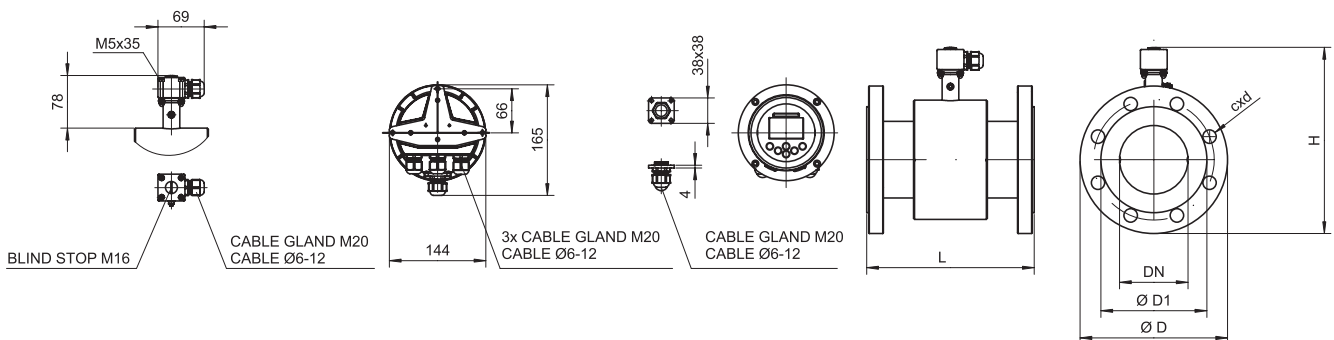

Tolerance of built-in length:  
 DN 10 – DN 150 L ± 5 mm  
 DN 200 – DN 1000 L ± 10 mm

Standard pressure:  
 DN 25 – DN 50 PN 40 / 150 lbs.  
 DN 65 – DN 350 PN 16 / 150 lbs.  
 DN 400 – DN 600 PN 10 / 150 lbs.

Max. electronics weight (including housing)	2 kg
Housing material	Aluminium + powder coating
Housing dimensions	Ø 143mm
Cable terminal	3+1xM20x1.5 IP68 cable gland
Electronics protection	IP68 / NEMA 6

# MAGX2 MAGB2 Reduced bore body

A special version of MAGX2 and MAGB2 with reduced flow profile for applications with zero straight pipe upstream and downstream allowance. A flowmeter with **UODO**.

Available for sizes DN50/40 (2"/1.1/2"), DN80/65 (3"/2.1/2"), DN100/80 (4"/3"), DN150/125 (6"/5")

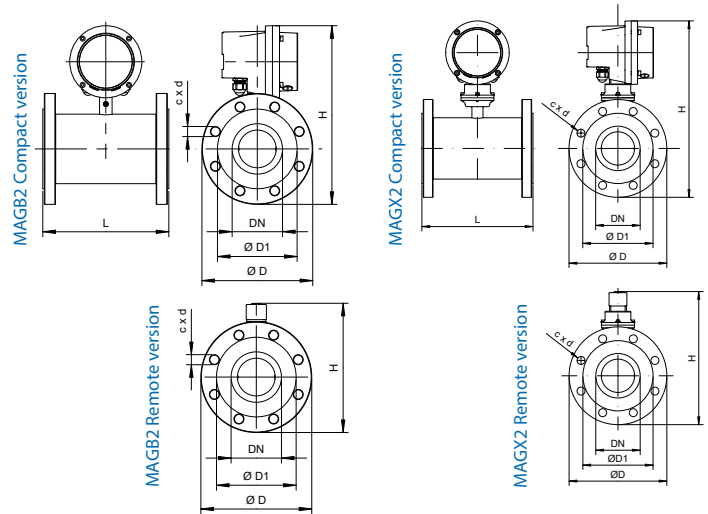

## TECHNICAL DRAWING DATA-SHEET IP68 TRANSMITTER

DIN				
DN	ØD	D1	CxØd	L
	[mm]	[mm]	[mm]	[mm]
50/40	165	125	4x18	200
80/65	200	160	8x18	200
100/80	220	180	8x18	250
150/125	285	240	8x22	300

ANSI				
DN	ØD	D1	CxØd	L
		[mm]	[mm]	[mm]
2"/1.1/2"	152.4	120.7	4x19.1	200
3"/2.1/2"	190.5	152.4	4x19.1	200
4"/3"	228.6	190.5	8x19.1	250
6"/5"	279.4	241.3	8x22.4	300

A new labeling - 50/40 means flange DN50 and reduced part of the body is with internal diameter of 40mm.



Arkon Flow Systems IOT solution for MAGX2 and MAGB2. No SIM cards, no dataplan needed.

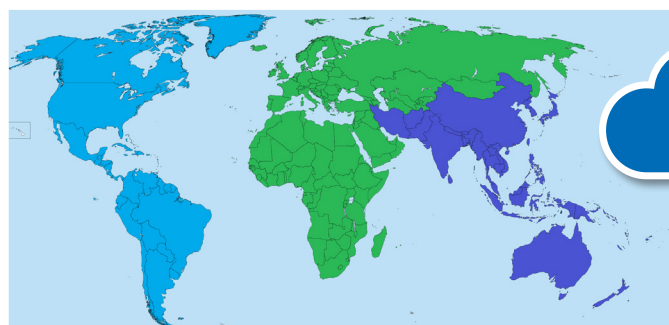

EU686 BAND  
US915 BAND  
AU915 BAND  
AS923 BAND

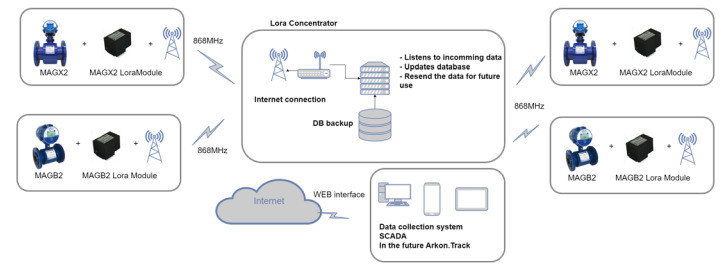
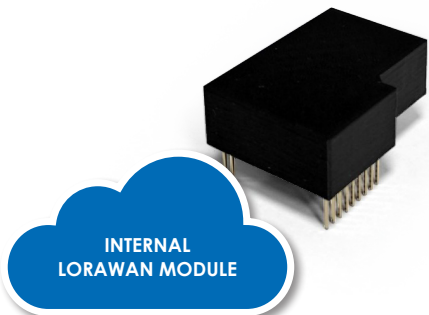

## COMPARISON

**GPRS module**  
Needs network coverage  
Needs SIM card  
No distance limits  
  
Needs dataplan  
Arkon.Track

VS.

**LORA module**  
Needs concentrator  
No SIM card  
Max 15 km to the concentrator  
No data plan needed  
Arkon.Track planned



## APPLICATIONS

- 🔧 **Water & Wastewater** - distribution networks, irrigation, sludge/sewage, water treatment, leakage management, desalination, marine, checking of pumps and water wells
- 🔧 **Public utilities** - water supply system, sewage systems, wastewater, industrial water, sludge, human waste, etc.
- 🔧 **Petrochemical/chemicals** - corrosive liquids, chemicals, industrial water, wastewater
- 🔧 **Paper & Pulp** - low concentration of pulp, additives, bleaches, colorants, liquor
- 🔧 **Construction** - building material slurry, sediment slurry, cement slurry, industrial water, etc.
- 🔧 **Hygienic/Sanitary** - potable water metering, food & beverages, pharmaceutical, medium, and high-density fluids, blending, dosing, batching

## ADVANTAGES

MAGE1 is an economic flowmeter with a carbon steel sensor and plastic transmitter that satisfies standard customer requirements. It is DC powered flowmeter (9-35 VDC) with 4-20 mA output, RS485 communication, and an internal data logger. Due to the plastic transmitter, it is a low-cost solution for your water application.

## FEATURES

- 🔧 Economic flowmeter with carbon steel sensor and plastic transmitter
- 🔧 Single power supply module that covers 9-35 VDC
- 🔧 Accuracy is  $\pm 0,5\%$  (0,5 to 10 m/s) of actual value
- 🔧 IP67 protection
- 🔧 Sizes from DN25 to DN250
- 🔧 Connections: DIN, ANSI, others on request
- 🔧 RS485 communication and 4-20mA current output

## MAGE1 IN REMOTE VERSION

For the cases where the compact mounting of the transmitter of MAGE1 would be inaccessible, the remote version should be used. The standard cable length is 6m, different lengths are available on request. The unit will be then mounted on the wall.

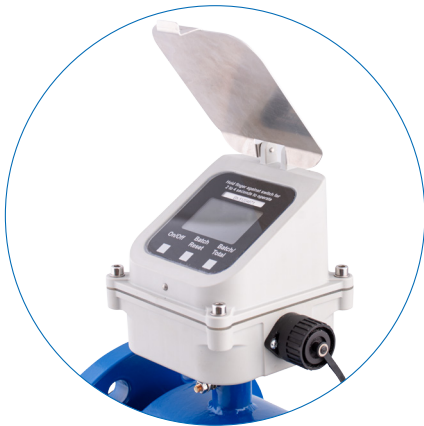

## TECHNICAL SPECIFICATIONS

Power supply	9-35 VDC
Communication	RS485 – Modbus RTU
Accuracy	$\pm 0,5\%$ (0,5-10 m/s) of actual value
Nominal size	25-250 mm
Connection types	DIN, ANSI flanged. Others on request
Digital communication	RS485 communication module
Analogue output	4-20 mA current output

## TRANSMITTER SPECIFICATIONS

Measurable media	Conductive fluids
Min. media electrical conductivity	$\geq 5\mu\text{S/cm}$ or $\geq 20\mu\text{S/cm}$ for demineralized water
Flow range	0.1 to 10 m/s
Displayed values	Flow range (m <sup>3</sup> /h, l/s, l/m, US Gal/min, UK Gal/min) Volume (m <sup>3</sup> , l, US Gal, UK Gal) Total Batch volume
Accuracy	$\pm 0,5\%$ (0,5-10 m/s) of actual value
Power supply	9-35 VDC
Comunication	Modbus RTU
Flow direction	Bi-directional measurement
Ambient temperature	- 20 to 60°C
Display	LCD 128 x 64 px graphical, sleep mode
Control	3 touch buttons
Housing material	Glass filled polyamide
Connection	CA 6 GS Connector
Electronics protection	IP67
Low flow cut off	2% of full scale
Other features	Test of excitation coils Earthing through 3rd and 4th electrodes Empty pipe detection
4-20 mA output	Max. current 24 mA
Digital communication	RS485 communication bus
Data logger	Flash memory 131072 records 15 seconds minimal record interval Saves date, time and total volume
Remote sensor cable length	6m as standard, other on request
Power/output cable length	3m as standard, other on request

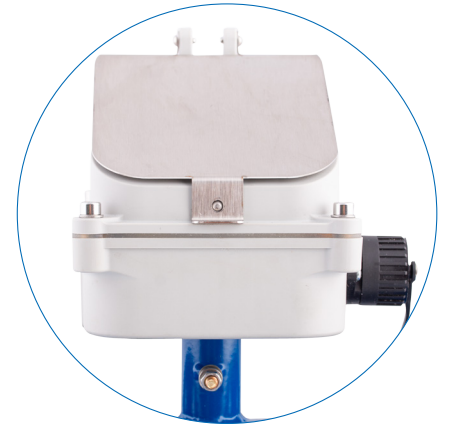

## SENSOR SPECIFICATIONS

Connection types	DIN, ANSI, Other types on request
Flange	Steel 1.0036 or higher
Nominal size	25-250 mm, other sizes on request
Maximum nominal pressure	PN 40/300 psi
Ambient temperature	- 20 to 60°C
Sensor	IP67
Liner	Hard Rubber, Hygienic Rubber, PTFE and other material on request
Electrodes	Stainless steel 1.4571 (316Ti), Hastelloy C-276, other on request
Measuring tube	Stainless steel 1.4301
Outer casing	Carbon steel (1.0036) as standard
External coating	Lacquered finish (anticorrosive)
Accessories options	Earthing rings for plastic and lined pipes
Coils resistance	100 $\Omega$
Other features	Earthing through 3 <sup>rd</sup> and 4 <sup>th</sup> electrodes



## APPLICATIONS

- ↳ **Water & Wastewater** - distribution networks, irrigation, sludge/sewage, water treatment, leakage management, desalination, marine, checking of pumps and water wells
- ↳ **Petrochemical/chemicals** - corrosive liquids, dosing of additives, chemicals, industrial water, waste water, pulp liquids
- ↳ **Paper & Pulp** - colorants, bleaches, additives
- ↳ **Construction** - building material slurry, industrial water
- ↳ **Sanitary** - potable water metering, food & beverage, pharmaceutical, medium and high density fluids, blending, dosing, batching

## ADVANTAGES

MAGS1 is a stand-alone version of flowmeter, which does not need a transmitter and can be operated on its own. If you need a low cost flowmeter without readable display and outputs, this will be the right one!

Inexpensive solution for application with existing PLC System with RS485 Modbus RTU communication system.

No display, fully operational electromagnetic flowmeter.

Cost-effective solution for installations where local display is not needed.

## FEATURES

The simple version is fed with 24VDC and has output/communication, a standard RS485 line on Modbus RTU protocol.

- ↳ Auto-diagnostics
- ↳ ±0.2% accuracy
- ↳ Cable length up to 500m

## TECHNICAL SPECIFICATIONS

Power supply	24VDC ± 10% @ 0.5A max
Communication	RS485 - Modbus RTU
Min. media electrical conductivity	≥5μS/cm ≥20μS/cm for demineralized water
Flow range	0.1 to 10 m/s
Accuracy	±0.2% (0.5 to 10m/s) of actual value
Connection types	DIN, ANSI, JIS flanged. Other types on request
Flange material	Carbon steel as standard. Dimensions according to DIN EN 1092-1, ASME B 16.5, JIS B 2239
Nominal size	25-900 mm (3/4" – 36")
Maximum nominal pressure	PN40/300 psi
Max. media temperature	70°C (158°F) for Hard Rubber liner, 130°C (266°F) for PTFE liner
Ambient temperature	-20 to 60°C (-4 to 140°F)
Sensor protection	IP68 (Nema 6), IP67 (Nema 5)
Liner	Hard Rubber, PTFE, other material on request, WRAS approved material available for sizes up to DN600
Electrodes	Stainless steel 1.4571 (316Ti), Hastelloy C-276, other on request
Measuring tube	Stainless steel 1.4301 dimensions according to EN 10027-2
Outer casing	Carbon steel (1.0036) as standard
External coating	Lacquered finish (anticorrosive)
Accessories options	Earthing rings for plastic and lined pipes
Coils resistance	80/100 Ω
Other features	Earthing through 3rd and 4th electrode Self-cleaning electrodes Empty pipe detection Auto-diagnostics Test of excitation coils Zero flow adjusting



## APPLICATIONS

Plastic flowmeter with power supply for multiple applications.

- Industrial wastewater discharge
- Water Recycling Systems
- Irrigation Water
- Well Pump Stations

## Agrimag

### FEATURES

- Polypropylene body material
- Flange clamps connection
- Sizes available: 25, 50, 80 mm
- 4 stainless steel electrodes
- Battery life: 1 year with meter in use, 3 years on stock
- Empty pipe detection and battery saving mode



- User friendly low-cost flowmeter
- 6x AA Battery powered
- No moving parts
- Fast and easy pipe connection

## AgrimagP

### FEATURES

- Sizes available: 25, 50, 80 mm
- 4 stainless steel electrodes
- Accuracy:  $\pm 1\%$  from 10 % to 100 % of full scale range
- Power supply range is 9-35VDC



- One frequency output – open collector
- External power supply
- No moving parts
- No earthing rings required

## AgrimagP2

### FEATURES

- Sizes available: 25, 50, 80 mm
- 4 stainless steel electrodes
- Accuracy:  $\pm 1\%$  from 10 % to 100 % of full scale range
- Power supply range is 9-35VDC
- Analogue output 4-20mA current loop
- RS485 Modbus RTU



- 4-20mA and RS485 outputs
- External power supply
- Internal Data logger
- No earthing rings required

## AGRIMAG SERIES TECHNICAL SPECIFICATIONS

Measurable media	Conductive fluids		
Min. Media electrical conductivity	≥20µS/cm		
Flow range	0.1 to 10 m/s		
Displayed values	Flow range (m <sup>3</sup> /h, l/s, l/m, US gal/min, UK gal/min), Volume (m <sup>3</sup> , l, US Gal, UK Gal), Total, Batch volume		
Accuracy	±1% of reading from 100% to 10% of full scale ±3% of reading from 10% of full scale to cut-off		
Full scale	1": 0.5 – 4.8 l/s	2": 1.9 – 18.9 l/s	3": 5.0 – 49.0 l/s
Power supply	Agrimag: 6 AA alkaline batteries	AgrimagP, AgrimagP2: 9-35VDC Power supply available in special connector	
Flow direction	Bi-directional measurement		
Ambient temperature	-12 to 50°C (10 to 130°F)		
Media temperature	0 to 60°C (32 to 140°F)		
Working pressure	150psi or 10.3 bars		
Body material	Glass filled polypropylen		
Connections	Flange clamps		
Electrodes	4x stainless steel electrodes		
Display	LCD 128 x 64 px graphical, sleep mode		
Control	3 touch buttons		
Low flow cut-off	2% of full scale		
Electronics protection	Nema 4X standard		
Other features	Test of excitation coils, Earthing through 3rd and 4th electrodes, Empty pipe detection - battery conservation		
Excitation frequency	Agrimag: 1/1.67s	AgrimagP, AgrimagP2: 6,25Hz	
Samples per Average	4 excitations		
Coils resistance	100Ω		
Frequency output (AgrimagP)	Open collector proportional to flow 0-1000Hz for 0-Qmax , Max switching voltage 24VDC, max. current 50mA		
Current loop output (AgrimagP2)	Max. current 24mA		
Digital communication (AgrimagP2)	RS485, MODBUS RTU		
Digital data logger (AgrimagP2)	Flash memory 131072 records, 15seconds minimal record interval. Saves Date, Time and Total volume		

### DIMENSIONS (in mm)

	A	B	C	D	E	F
25 mm	100	130	80	25.4	139.7	41.402
50 mm	100	150	82.55	50.8	139.7	51.562
80 mm	100	180	111	76.2	185	64.8

### FITTING KITS AVAILABLE FOR MANIFOLD

	25 mm	50 mm	80 mm
Male BSP	1" Male BSP	2" Male BSP	3" Male BSP
Female NPT	1/2", 3/4" and 1" Female NPT	2" Female NPT	3" Female NPT
Male NPT	3/4", 1" and 1.1/4" Male NPT	2" Male NPT	3" Male NPT
Male NPT in SS	1" Male NPT	1.1/2" and 2" Male NPT	1.1/2" and 2" Male NPT

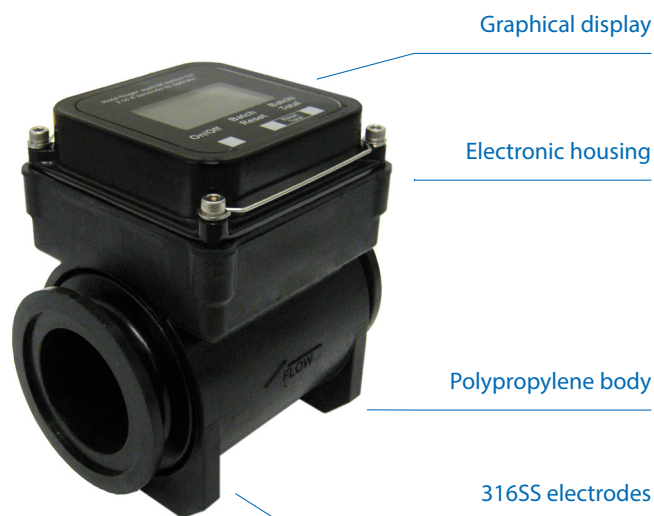

# VeriMAG1 VeriMAG2

## VERIFICATORS

VeriMAG1 (for MAGB1 and MAGB2 verification) and VeriMAG2 (for MAGX2 verification) are stand-alone field verification tools for use with our range of electromagnetic flow meters, that enables users to test the integrity of flow meter systems. It offers possibility of verification of meter functionality without taking the meter out of the pipeline and interrupting functionality and dry test can also be performed on a removed flowmeter.

The verification process consists of a large number of separate tests, including performance and factory set calibration data verification.

The vericator is a standalone field device with built in storage and there is no requirement for a carry around field laptop to store data as up to 100 verifications can be stored and then downloaded after the site visit.

## SPECIFICATION

- 📏 **Dimensions** - 143×145 mm
- ⚖️ **Weight** - approx. 2 kg
- 📺 **Display** - graphic display - 128x64 px
- 👉 **Keypad** - touch buttons
- 🔋 **Power supply** - Internal rechargeable battery good for 20+ tests
- 🛡️ **Protection** - IP65
- 🌡️ **Temperature range** - 0 to 50°C (32 to 122°F)



- 📡 With the ever expanding water treatment and distribution networks to meet public needs along with increasing regulatory demands, there is a requirement for a reliable, safe and secure application for remote monitoring of vast networks.
- 📡 Our telemetry system arkon.track offers remote monitoring of water applications within the industry from small treatment plants to country wide water distribution networks.
- 📡 Each customer is issued with a unique user name and password which enables them to log in and view device locations on a map and see live data feeds as well as historical data and charts for each instrument.
- 📡 One of the possibilities is to run the Arkon.track on your own server.

arkon  
.track



- 🌐 Internet of Things (IoT) is playing a key role in transforming our live. Industrial Internet of Things brings together brilliant machines, advanced analytics, and people at work.
- 📡 By combining machine-to-machine communication with industrial big data analytics, IoT is driving unprecedented levels of efficiency, productivity, and performance. And as a result, industrial companies in original equipment manufacturing, chemicals, food and beverage, automotive, steel, and many other industries are experiencing transformative operational and financial benefits.
- 📡 Our products are ready to be connected to your modern network. Modular design offers future proof technology of our electromagnetic flowmeters.

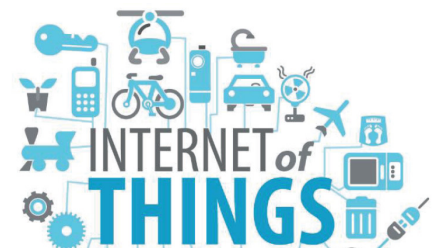

## APPLICATIONS

- Water and wastewater measurement
- Monitoring and controlling of Heating, Ventilation and Air Conditioning (HVAC) systems
- Automated process control
- Effluent measurement
- Cost effective large pipe measurement
- Automated process control
- In-line flowmeter performance verification, pump testing and inspection, leakage and blockage detection

## ADVANTAGES

USCXseries offers Ultrasonic clamp-on flowmeters based on transit time method of measurement, suitable for various kinds of liquids with wide range of process outputs including RS485, Modbus RTU, Profibus and HART compatible output. With ultrasonic clamp-on meters you do not need to stop the process. USCXseries offers easy installation with own wizard for correct installation. Various models and modules offer solutions for one channel, two channel permanent installations or portable device for on site maintenance and control for pipe sizes up to 6500 mm.

## USCX100

Standard Clamp-On Ultrasonic Flowmeter for basic applications

### FEATURES

- Low cost
- Wide range of process outputs including RS485, Modbus RTU and HART compatible output
- PT100 input for heat quantity (thermal energy) measurement
- Innovative installation wizard for quick and intuitive programming
- Bi-directional measurement with totaliser function
- Configuration can be changed to suit customer requirements
- Temperature range for sensor from -30°C to +80°C (-22 °F to + 176 °F) and pipe diameter range from 10 mm to 3000 mm
- Flow velocity range from 0.01 to 25 m/s
- Accuracy of to 3% of measured value depending on application and up to 0.5% of measured value with process calibration
- Easy transmission of measured and logged data



## USCX150

Advanced Clamp-On Ultrasonic Flowmeter suitable from basic to advanced applications



### FEATURES

- Pipe diameter range from 10 mm to 6500 mm
- Temperature range for sensor from -30 °C to +250 °C (-22 °F to +482 °F), higher temperatures available on request
- Lockable and sturdy IP66 polycarbonate flowmeter enclosure
- Selectable three-line LCD display and full keypad
- Up to ten input or output slots available
- Measurement of two flows simultaneously with sum, average, difference and maximum calculations
- Communication options via RS485, Modbus RTU, Profibus PA and HART compatible output
- Process output options including current, open-collector, relay
- Current inputs for temperature, pressure and density
- Large data logger and software for sampling and data transfer
- Optional heat quantity (thermal energy) measurement

## FEATURES

- ▶ Robust IP 65 enclosure with added rubber shock protector
- ▶ Selectable three-line LCD display and full keypad
- ▶ Battery life up to 26h with standard NiMH AA batteries for simple replacement
- ▶ Lightweight and tactile for easy one-handed use
- ▶ Stainless steel sensors, cable and connectors as standard
- ▶ Innovative installation wizard for quick and intuitive programming
- ▶ Full instrument diagnostics and scope function
- ▶ Large data logger and software for sampling and data transfer
- ▶ Crush-proof IP67 transport case or lightweight soft case and special waterproof solution available for harsh environmental conditions



## TECHNICAL SPECIFICATIONS

	USCX100	USCX150	USCX200
Pipe diameter range	10 mm to 3000 mm	10 mm to 6500 mm	10 mm to 6500 mm
Flow velocity range	0.01 to 25 m/s		
Resolution	0.25 mm/s		
Repeatability	0.15% of measured value ± 0.015 m/s		
Accuracy	Volume flow:		
	±1% to 3% of measured value depending on application		
	±0.5% of measured value with process calibration		
	Flow velocity (mean):		
	±0.5% of measured value		
Turn down ratio	1/100 (equivalent to 0.25 ... 25m/s)		
Measurement rate	100 Hz		
Response time	1 s (standard), 90 ms (optional)		
Damping of display value	0 ... 99 s (selectable by user)		
Gaseous and solid content liquid media	< 10% of volume		
Enclosure type	Wall mounted, optional pipe stand and brackets available	Only wall mounted	Hand-held
Degree of protection	IP 66 according to EN 60529	IP 66 according to EN 60529	IP 65 according to EN 60529
Operating temperature	-10°C to +60°C (+14°F to +140°F)		
Housing material	Die-cast aluminium	Polycarbonate (UL94 V-0)	ABS (UL 94 HB)
Measurement channels	1	2	1
Power supply	100-240 VAC 50/60 Hz 9-36 VDC	100-240 VAC 50/60 Hz 9-36 VDC	Internal rechargeable batteries: 4x NiMH AA2850 mAh Power adapter: 100-240 VAC input, 9VDC output External battery pack: 12 V 105 Ah
Display	LCD graphic display, 128 x 64 dots, backlit		
Dimensions	120 (h) x 160 (w) x 81 (d) mm	237 (h) x 258 (w) x 146 (d) mm	228 (h) x 72/124 (w) x 58 (d) mm
Weight	Approx. 750 g	Approx. 2.3 kg	Approx. 650 g
Power consumption	< 5 W	< 10 W	< 3 W
Operating languages	English, French, German, Dutch, Spanish, Italian, Russian, Czech, Turkish, Romanian (other on request)		
Communication	RS232, USB cable, Modbus RTU via RS485	RS232, USB cable, RS485, Modbus RTU, HART, Profibus PA	RS232, USB cable
Transmitted data	Measured and totalised value, parameter set and configuration, logged data		
Storage capacity	N/A	Approx. 30 000 measurements with logger size 5 MB Approx. 100 000 measurement with logger size 16 MB	Approx. 30 000 measurements with logger size 5 MB Approx. 100 000 measurements with logger size 16 MB
Process inputs	Temperature by PT100 (clamp-on sensor), 3 or 4 wire circuit Current 0/4-20mA active or passive	Temperature by PT100 (clamp-on sensor), 3 or 4 wire circuit Current 0/4-20mA active or passive	N/A
Process outputs	Current 0/4-20mA active or passive Digital open-collector Digital relay Voltage Frequency	Current 0/4-20mA active or passive Digital open-collector Digital relay Voltage Frequency HART compatible 4-20mA	N/A

## FLOW INDICATORS

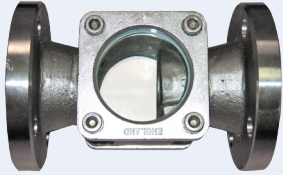
	APPLICATION	DESCRIPTION	PARAMETERS	IMAGE
<b>Ball Flow</b>	Maintaining demineralised water rinsing essential to electronics components manufacture. Showing the presence of condensate in steam return lines. Indicating chemical dosing on water treatment plants. Ensuring that flow of cooling water is maintained to specialised medical equipment. Detecting changes in colour and condition of liquids during processing.	The ball flow indicator is a single sided indicator. The white PTFE ball rises when there is flow of liquids or gasses and is clearly visible from a distance.  Suitable for applications where a constant flow is required, such as cooling lines or for showing the presence of condensate in steam return lines.	Pressure: up to 16 bar. Temperature: up to 200°C Sizes: 15 to 40 mm Material: Stainless steel Connections: BSP and NPT	
<b>Spinner Flow</b>	Pump, compressor and diesel engine protection. Ensuring that flow of cooling water is maintained to specialised welding equipment. Detecting changes in colour and condition of liquids during processing. Indication of air entrainment. Early warning of overheating, bearing or seal failure.	The bright yellow spinner can be seen in the glass dome when there is flow.  The Spinner flow indicator is a single sided indicator. The spinner starts to rotate when flow starts. The design offers low pressure losses and is suitable for installation in both horizontal and vertical pipework.	Pressure: up to 10 bar. Temperature: up to 100°C Sizes: 15 to 40 mm Material: Gunmetal Connections: BSP and NPT	
<b>Paddle Wheel</b>	Checks the flow of liquid in pipeline. Flow monitoring in full pipes.	Flow indicators with a highly visible PTFE paddle wheel to indicate the flow of liquids in the line. Suitable for clear and cloudy liquids.  It can be used in vertical or horizontal lines and is ideal for flow monitoring in full pipes.	Pressure: up to 60 bar. Temperature: up to 250°C Sizes: 15 to 40 mm Materials: Carbon Steel, St. steel and Gunmetal Connections: BSP, NPT and ANSI150	
<b>Plain Sight Flow</b>	Checks for the presence of liquid where there is intermittent flow, partially filled lines or entrained air. Leak detection.	For viewing flow conditions in applications with intermittent flow, entrained air and partially filled pipes. A special version for use with steam and condensate uses borosilicate glass to ensure good long-term visibility.  It can be used in vertical or horizontal lines.	Pressure: up to 60 bar. Temperature: up to 250°C Sizes: 15 to 200 mm Materials: Carbon Steel, St. steel and Gunmetal Connections: BSP, NPT and ANSI150	
<b>Tube Flow</b>	Checks for the presence of liquid where there is intermittent flow, partially filled lines or entrained air.	The tube indicator allows a 360° visual indication of the flow and contents in the pipes.  It has a plain straight through borosilicate glass tube with stainless steel flanged ends and is used to check for the presence of liquid where there is intermittent flow, partially filled lines or entrained air.	Pressure: up to 10 bar. Temperature: up to 150°C Sizes: 15 to 200 mm Material: Stainless steel Connection: ANSI150	
<b>Flap Flow</b>	Checks the flow rate of liquid in a pipeline. Plant safety device where you need to maintain a constant flow.	The flap indicates flow on an easy to read scale. It is for use with liquids or steam. It is particularly suited for applications with low flow as the flow must move the flap to pass through the meter. It is ideal as a plant safety device where you need to maintain a constant flow, for example in lubricating or cooling systems.	Pressure: up to 60 bar. Temperature: up to 250°C Sizes: 15 to 200 mm Materials: Carbon Steel, St. steel and Gunmetal Connections: BSP, NPT and ANSI150	
<b>Window</b>	Provides for viewing the contents of a vessel or tank.	Circular sight glass for bolting or welding to tanks, vessels or pipes to allow viewing of the contents. This model is designed to provide a window for viewing the contents of a vessel or tank. Normally these are welded to the tank, but can be supplied suitable for bolting to a vessel or a pipe flange if required.	Pressure: up to 40 bar Temperature: up to 250°C Sizes: 40 to 200mm Materials: Carbon steel and Stainless steel	

# FLOW VELOCITY, FLOW RATE, QUALITY MANAGEMENT SYSTEM

## FLOW VELOCITY

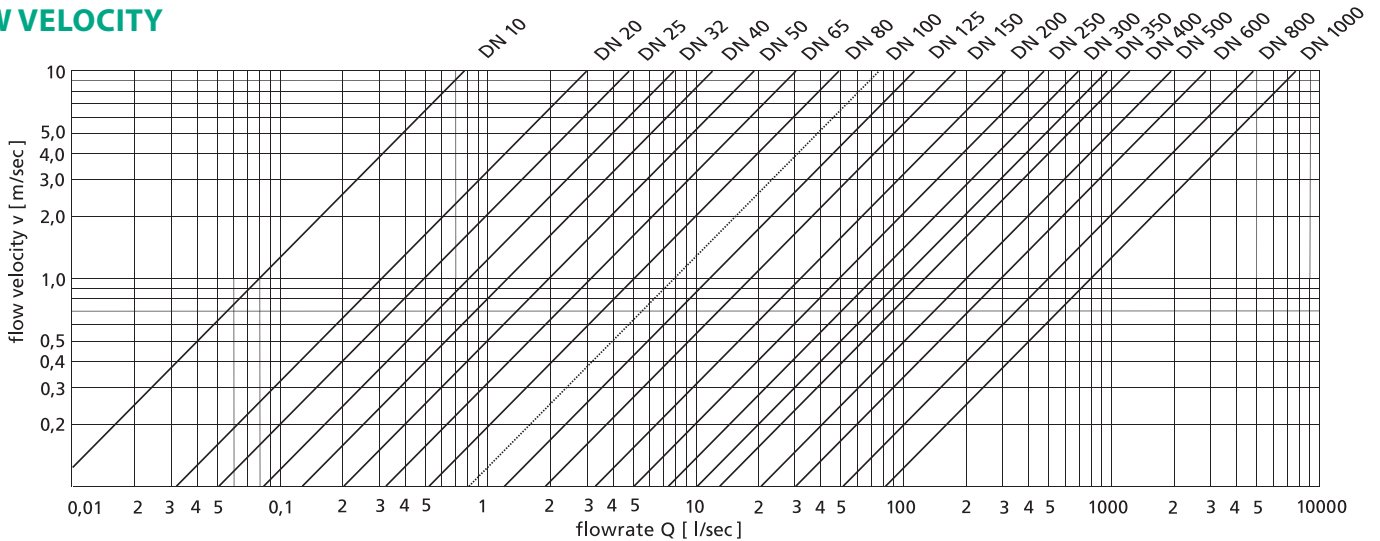

## FLOW RATE

DN	FLOW RATES [l/s]					FLOW RATES [m³/h]				
	Q 5%	QN	QN 50%	QN 100%	Q MAX	QN 5%	QN	QN 50%	QN 100%	Q MAX
10	0.04	0.2	0.39	0.79	0.8	0.14	0.8	1.41	2.83	3.20
15	0.09	0.5	0.88	1.77	2	0.32	2	3.18	6.36	8.00
20	0.16	0.9	1.57	3.14	3.6	0.57	3.2	5.65	11.31	12.8
25	0.25	1.4	2.45	4.91	5.6	0.88	5	8.84	17.67	20.00
32	0.4	2.2	4.02	8.04	8.8	1.5	8	14.5	29	32.0
40	0.6	4	6.3	12.6	16	2.3	13	22.6	45.2	52.0
50	1	6	9.8	19.6	24	3.5	20	35.3	70.7	80.0
65	1.7	9	16.6	33.2	36	6	35	59.7	119.5	140.0
80	2.5	14	25.1	50.3	56	9	50	90.5	181	200.0
100	3.9	20	39.3	78.5	80	14	80	141	283	320
125	6	30	61	123	120	22	150	221	442	600
150	9	50	88	177	200	32	200	318	636	800
200	16	100	157	314	400	57	300	565	1131	1200
250	25	150	245	491	600	88	500	884	1767	2000
300	35	200	353	707	800	127	800	1272	2545	3200
350	48	300	481	962	1200	173	1000	1732	3464	4000
400	63	400	628	1257	1600	226	1300	2262	4524	5200
450	80	444	795	1590	1778	288	1598,4	2862	5724	6400,8
500	98	600	982	1963	2400	353	2000	3534	7069	8000
600	141	800	1414	2827	3200	509	3000	5089	10179	12000
700	192	1000	1924	3848	4000	693	4000	6927	13854	16000
800	251	1200	2513	5027	4800	905	5000	9048	18096	20000
900	318	1500	3181	6362	6000	1145	6000	11451	22902	24000
1000	393	2000	3927	7854	8000	1414	8000	14137	28274	32000

Q5% recommended minimum flowrate / QN recommended nominal flowrate (expected working flowrate)

Q50% recommended maximum flowrate (maximum flowrate for industrial use) / Q100% maximum applicable flowrate (maximum flowrate with guaranteed accuracy)

QMAX maximum applicable overload (flowmeter is still measuring)

## QUALITY MANAGEMENT SYSTEM & TRACEABILITY

Arkon Flow Systems quality management system is certified according to standard ISO 9001:2015.

All main processes of manufacturing, development, sale, and services are certified and audited yearly by Bureau Veritas Certification.

All manufactured flowmeters are carefully tested according to internal standards and calibrated in independent laboratories specialized in flow rate and flow volume calibration of liquids.

Arkon main standards are traceable directly to Czech national standards in the Czech Metrology Institute (CMI). CMI is the Czech national metrology body and is traceable to international standards. CMI laboratories are accredited by the Czech institute for accreditation, a member of European co-operation for accreditation.



## RECOMMENDED POSITION FOR SENSOR INSTALLATION

### SENSOR INSTALLATION REQUIREMENTS

Proper installation is extremely important in order for your flowmeter to work correctly. There are minimum sensor installation requirements that need to be respected at all times. Please note that Arkon cannot warranty any installation which does not comply with these requirements:

#### HORIZONTAL STANDARD MOUNTING

The sensor tube must always remain full. The best way to achieve this is to locate the sensor in a low section of pipe, see the following picture.

It is mandatory to install the sensor in a section of straight pipe with at least 5 times the pipe diameter before sensor and 3 times after sensor.

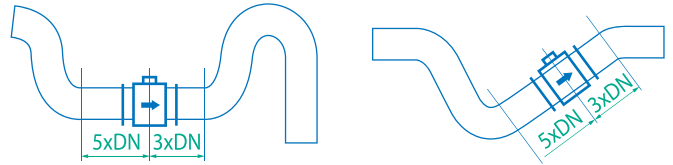

#### PIPE REDUCERS

If the pipe diameter is not the same as the diameter of sensor, then pipe reducers can be used. So as not to lose accuracy of the measurement, the slope of reducers should not exceed 8°.

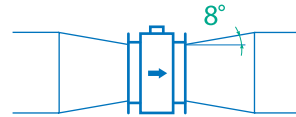

#### VERTICAL MOUNTING

When the sensor is mounted on a vertical section of pipe, the flow direction must be upwards. In the case of a downward flow direction, air bubbles can collect in the sensor and the measurement could be unstable and inaccurate.

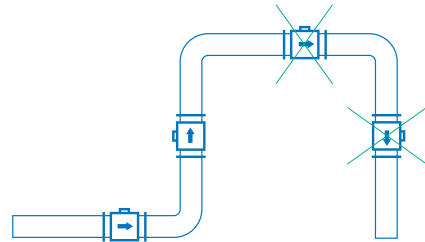

#### PUMPS

Never install the sensor on the suction side of a pump or on a section of pipe where a vacuum is possible. Avoid negative pressure in the meter installation.

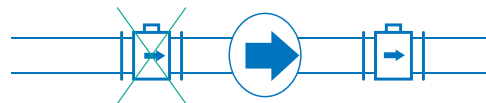

#### VALVES

Suitable location of a shut off valve is downstream of a sensor.

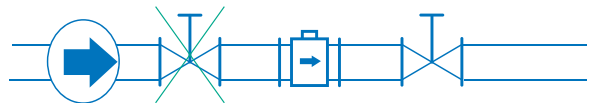

## REMOVAL DURING MAINTENANCE

If the application requires removal of the sensor for periodic maintenance, it is recommended to install a bypass section as the drawing below.

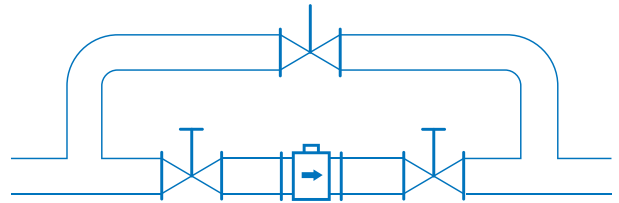

## EARTHING

All flowmeters must be earthed. Maximum resistance of the sensor to earth is <math><1\text{ ohm}</math>. All the components in the loop, including flowmeter, pumps (especially submersible) valves, pipework, tanks and medium, should all be at the same earth potential. Problems can occur when different potentials are present which can happen, especially with submersible pumps. On applications with non-lined metal pipes and tanks it is enough to earth the flowmeter to the pipe's flanges. On applications where pipes and tanks are manufactured from plastic or metal with non-conductive liner it is necessary that earthing rings are also installed to ensure the flowmeter works correctly.

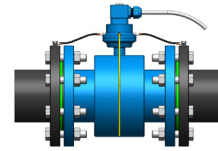

Conductive (metal) pipe

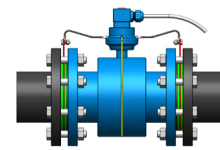

Non-conductive (plastic, lined) pipe

## REMOTE MOUNTING SYSTEM

Wall



DIN Rail



Pannel

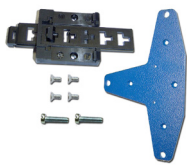
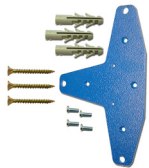

### REMOTE CONNECTION CABLE

UNITRONIC LiYCY (TP) 0035 810, 2x2x0.5 mm for MAGX2

UNITRONIC Li2YCY (TP) 0031 325, 2x2x0.34 mm for MAGB1 and MAGB2

## CERTIFICATION

MAGX2  
MAGS1  
MAGB2  
MAGE1  
Agrimag / AgrimagP / AgrimagP2

EMC and ES certified  
PED 92/23 EC  
CE  
RoHS 3

OIML R49 for MAGX2 and MAGB2  
MID certification for MAGX2 and MAGB2  
IP68 for MAGX2, MAGB2  
GOST certification  
WRAS liner certification  
Company is ISO 9001: 2015 certified

ISO 9001  
BUREAU VERITAS  
Certification



Model	Ordering code							Description
MAGX2 IP68								Standard calibration
MAGX2 OIML IP68	1	2	3	4	5	6	7	OIML R49 Version (DN25 - DN300)
MAGX2 MID IP68								MID Version - M-001, Class 2 (DN25 - DN300)
	T							MAGX2 main board, display, 6 buttons control unit
		5						<b>Power supply module</b>
			CM					Version 5 - 12-35 VDC, 90-250 VAC including battery back-up option
								Sensor to transmitter communication module - Version 8
								<b>Remote mounting kit</b>
				N				None
				W				WALL mounting kit (including 6 m cable)
				P				PANEL mounting kit (including 6 m cable)
				D				DIN-Rail mounting kit (including 6 m cable)
								<b>Output 1</b>
				N				None
				C				4 -20 mA current output signal module
				EP				External pressure sensor**
								<b>Output 2</b>
				N				None
				P				Pulse output module
				P2				Pulse 230
				ET				External temperature sensor**
								<b>Communication</b>
				N				None
				232				RS232 communication module, including 1.8 m cable
				USB				USB communication module, including 1.8 m cable
				BTO				Bluetooth communication module
				3G				3G/GPRS/GSM communication module
				485				RS485 communication module, distance up to 1 km
				TCP				TCP/IP communication module
				WIFI				Wi-Fi communication module
				MBUS				M-BUS communication module
				MTCP				MODBUS TCP module
				LORA				LoRaWAN communication module*

Example

MAGX2	T	5	CM	N	C	N	USB
-------	---	---	----	---	---	---	-----

\*\* Input measuring probe not included  
\* Frequency plan needs to be specified

Model	Ordering code					Description
MAGX2 Sensor	1	2	3	4	5	
	D					<b>Connection</b>
	A					DIN
	DS					ANSI
	DSS					DIN Flange St. St.
	AS					DIN St.St.Flange & St. St. body
	ASS					ANSI Flange St. St.
	S					ANSI St. St. body
	SSS					DIN 11851
	J					DIN 11851 St. St. body
	E					JIS
	TD					Table E
	T					Table D
	W					Tri-clamp
						Wafer
						<b>Size</b>
		10 / 3/8	200 / 8			10 mm / 3/8"
		15 / 1/2	250 / 10			15 mm / 1/2"
		20 / 3/4	300 / 12			20 mm / 3/4"
		25 / 1	350 / 14			25 mm / 1"
		32 / 1.1/4	400 / 16			32 mm / 1.1/4"
		40 / 1.1/2	450 / 18			40 mm / 1.1/2"
		50 / 2	500 / 20			50 mm / 2"
		65 / 2.1/2	600 / 24			65 mm / 2.1/2"
		80 / 3	700 / 28			80 mm / 3"
		100 / 4	800 / 32			100 mm / 4"
		125 / 5				125 mm / 5"
		150 / 6				150 mm / 6"
						<b>Liner</b>
			HR			HARD RUBBER
			PT			PTFE
			SR			SOFT RUBBER
			NR			HYGIENIC RUBBER
			CT			E-CTFE
						<b>Pressure</b>
			150			150 psi
			300			300 psi
			10			PN10
			16			PN16
			25			PN25
			40			PN40
						<b>Electrodes</b>
			SS			Stainless steel 1.4571 (316Ti)
			HA			Hastelloy -276
			TI			Titanium
			PL			Platinum

Example

MAGX2 Sensor	D	100	HR	16	HA
--------------	---	-----	----	----	----

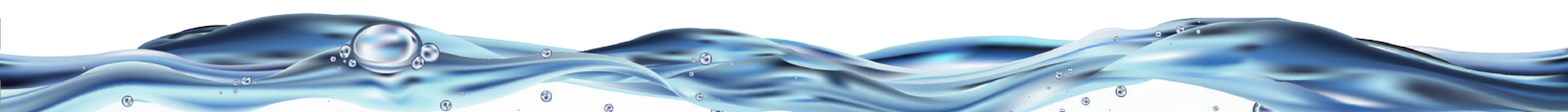

Model	Ordering code							Description
MAGB2	1	2	3	4	5	6	7	OIML R49 Version (DN25 - DN300)
MAGB2 OIML								MID Version - M-001, Class 2 (DN25 - DN300)
MAGB2 MID								
C								<b>Version</b> Compact
W								Remote: WALL mounting kit (including 6m cable)
P								Remote: PANEL mounting kit (including 6m cable)
D								Remote: DIN-Rail mounting kit (including 6m cable)
								<b>Connection type</b>
D								DIN
A								ANSI
								<b>Size</b>
		25 / 1	200/8					25 mm / 1"
		32 / 1.1/4	250/10					32 mm / 1.1/4"
		40 / 1.1/2	300/12					40 mm / 1.1/2"
		50 / 2	350/14					50 mm / 2"
		65 / 2.1/2	400/16					65 mm / 2.1/2"
		80 / 3	450/18					80 mm / 3"
		100 / 4	500/20					100 mm / 4"
		125 / 5	600/24					125 mm / 5"
		150/6						150 mm / 6"
								<b>Liner material</b>
								HARD RUBBER
								SOFT RUBBER
								PTFE
								HYGIENIC RUBBER
								Pressure
								150 psi
								300 psi
								PN 10
								PN 16
								PN 25
								PN 40
								<b>Electrodes</b>
								Stainless steel 1.4571 (316Ti)
								Hastelloy -276
								Titanium
								Platinum
								<b>Expansion modules</b>
								4-20I
								4-20 mA current output
								4G
								4G LTE/GPRS/GSM module
								485I
								RS485 module
								485N
								RS485 module non-isolated
								LR
								LoRa module*
								NB
								NB-IOT module
								<b>External input option 1</b>
								External pressure probe
								<b>External input option 2</b>
								External temperature probe

Example

MAGB2	C	D	100	HR	16	HA	3G	EP	* Frequency plan needs to be specified
-------	---	---	-----	----	----	----	----	----	--

Model	Ordering code					Description
MAGS1	1	2	3	4	5	
						Connection
						DIN
						ANSI
						Size
			25-900			25-900 mm
			1-24			1"-24"
						Liner
						HARD RUBBER
						PTFE
						SOFT RUBBER
						HYGIENIC RUBBER
						Pressure
						150 psi
						300 psi
						PN10
						PN16
						PN25
						PN40
						Electrodes
						Stainless steel 1.4571 (316Ti)
						Hastelloy -276
						Titanium
						Platinum

Example

MAGS1	D	100	HR	16	HA
-------	---	-----	----	----	----

Model	Ordering code							Description
MAGE1	1	2	3	4	5	6	7	
								<b>Version</b>
C								Compact
R								Remote
								<b>Connection type</b>
	D							DIN
	A							ANSI
								<b>Size</b>
		25 / 1	100 / 4					25 mm / 1"
		32 / 1.1/4	125 / 5					32 mm / 1.1/4"
		40 / 1.1/2	150 / 6					40 mm / 1.1/2"
		50 / 2	200 / 8					50 mm / 2"
		65 / 2.1/2	250 / 10					65 mm / 2.1/2"
		80 / 3						80 mm / 3"
								<b>Liner material</b>
								HARD RUBBER
								SOFT RUBBER
								PTFE
								HYGIENIC RUBBER
								<b>Pressure</b>
								150 psi
								300 psi
								PN 10
								PN 16
								PN 25
								PN 40
								<b>Electrodes</b>
								Stainless steel 1.4571 (316Ti)
								Hastelloy -276
								Titanium
								Platinum

Example

MAGE1	C	D	25	HR	40	HA
-------	---	---	----	----	----	----

Model	Ordering code		Description
Agrimag/AgrimagP/AgrimagP2	1	2	
			<b>Size</b>
	25		25 mm
	50		50 mm
	80		80 mm
			<b>Connections</b>
		NPT	NPT female (only for 25 mm)
		MAN	Manifold

Example

Agrimag	25	NPT
---------	----	-----

Please note that any order placed without details regarding flow-range (for example: 0-50 m<sup>3</sup>/hr or 0 -100 l/s) and Pulse Output (for example 1 pulse/litre) will be processed with standard settings.

Please note for application where all pipes and tanks are manufactured from "non-conductive material", earthing rings are "mandatory" to ensure the accuracy of the measurement.

When placing orders for applications such as aggressive and corrosive liquids, please advise us about the specifics of the application and installation on your enquiry form or order. This will enable us to recommend or help you in choosing the best product for your application.

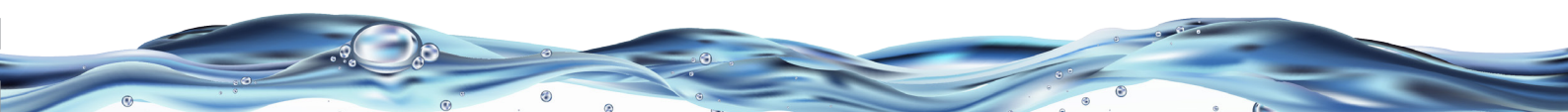

**Arkon Flow Systems, s.r.o.** is a Czech based company involved in the design, production, development, distribution of electromagnetic flowmeters & our range of products are complemented with ultrasonic flowmeters, level meters, Parshall flumes and flow indicators.

We offer a flexible approach to customer's needs, by offering customized solutions for each application.

Arkon Flow Systems offers its products via a worldwide distributor network. Our products are used in over 20 countries with applications such as Water Treatment & Distribution, Waste Water Management, Irrigation, Mining & Chemical Industry as well as projects where efficiency and accuracy coupled with smart technology matters the most.

## OUR NETWORK

We offer our products to customers via worldwide distributors. Some of the countries where we have official distributors are:

### EUROPE

Denmark, Finland, France, Greece, Ireland, Latvia, Portugal, Ukraine, United Kingdom

### NORTH AND SOUTH AMERICA

Canada, Colombia, Chile, Mexico, Peru

### ASIA

Australia, China, Indonesia, Malaysia, New Zealand, Singapore, South Korea, Sri Lanka, Thailand, Vietnam

### MIDDLE EAST

Bahrain, Egypt, Iraq, Jordan, Kuwait, Oman, Pakistan, Qatar, Saudi Arabia, Turkey, United Arab Emirates

### AFRICA

South Africa

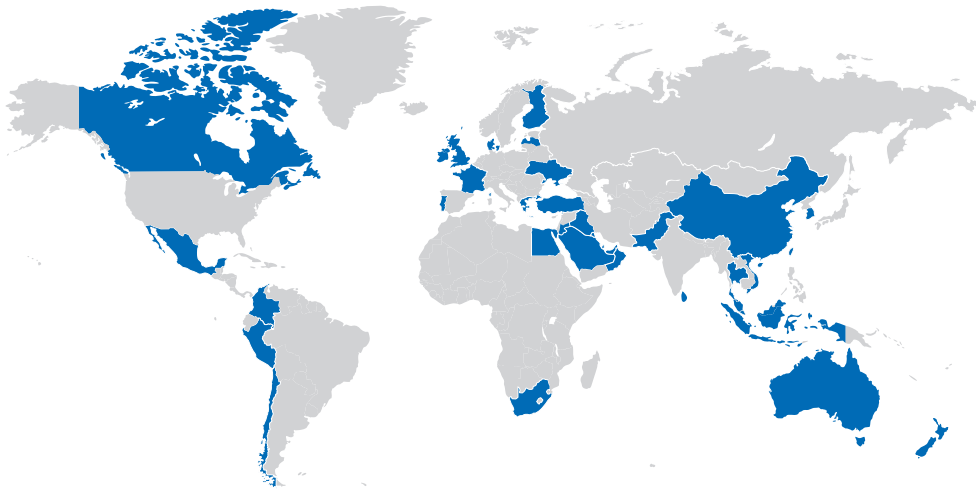

## REPRESENTATIVE:

### Arkon Flow Systems

Nováčkova 11, 614 00 Brno, Czech Republic  
Tel. +420 543 214 822, Tel./Fax +420 543 215 249  
Enquiries/Orders/General questions: [arkon@arkon.co.uk](mailto:arkon@arkon.co.uk)  
Marketing support/brochures: [info@arkon.co.uk](mailto:info@arkon.co.uk)  
Technical support: [support@arkon.co.uk](mailto:support@arkon.co.uk)  
[www.arkon.co.uk](http://www.arkon.co.uk)



Co-funded by  
the European Union

ISO 9001

BUREAU VERITAS  
Certification



[www.arkon.co.uk](http://www.arkon.co.uk)

Version 03/2026

