

# MQU & MHU User Guide

Ultrasonic open channel  
flowmeter & level meter



---

**Arkon Flow Systems**  
Přízova 1-3, 602 00 Brno, Czech Republic  
Tel. +420 543 214 822, Tel./Fax +420 543 215 249  
Enquiries/ Orders/ General questions: [office@arkon.co.uk](mailto:office@arkon.co.uk)  
Marketing support/ Brochures: [marketing@arkon.co.uk](mailto:marketing@arkon.co.uk)  
Technical support: [support@arkon.co.uk](mailto:support@arkon.co.uk)  
[www.arkon.co.uk](http://www.arkon.co.uk)

# List of Contents

<b>1. Specifications .....</b>	<b>2</b>
<b>2. Technical data – Control unit terminal board .....</b>	<b>3</b>
2.1. Technical conditions.....	3
2.2. Technical data.....	4
<b>3. Mounting kit .....</b>	<b>8</b>
3.1. Possibilities of assembly - compact version .....	8
3.2. Possibilities of assembly - remote version .....	9
<b>4. Instructions for use .....</b>	<b>11</b>
4.1. A graphic structure of individual menu MQU.....	12
4.2. Explanation about service password .....	12
4.3. Instructions for use - detailed menu description.....	13
<b>5. Instructions for adjustment – detailed menu description .....</b>	<b>15</b>
<b>6. Example of smart unit adjustment .....</b>	<b>23</b>
<b>7. Smart MQU – data acquisition .....</b>	<b>24</b>
7.1. Transfer panel.....	24
7.2. Statistic panel .....	24
7.3. Flow panel .....	25
7.4. Troubleshooting.....	26
<b>8. Appendix .....</b>	<b>29</b>
8.1. Warranty .....	29
8.2. Contact.....	29



# 1. Specifications

## Basic user description:

The MQU 99 unit is an ultrasonic flowmeter that is intended for flow profile measurements (e.g. Parshall flumes, Thomson overflows, combined profiles, etc.). The flowmeter measures level height H, current flow Q and total volume. Furthermore, the device is provided with a number of output, control and statistic functions. The flowmeter consists of one reader and one or two ultrasonic probes. The unit is configured as a single-channel (one measured profile) or double-channel (two measured profiles) unit. The principle of measurement is identical for both types. For simplicity, a brief description for the single-channel unit follows.

## Measurement functions

The MQU unit measures a level height H in open measurement profiles by means of ultrasonic probes. The unit calculates current flow Q and total volume based on the level height being measured. The curve of  $Q = f(H)$  is entered in the unit as the formula (6 options). The formulae used most frequently are as follows:

$$Q = A \times H^B$$

$$Q = A \times (H+D)^B + C$$

$$Q = A \times H^B + E \times (H+Z)^F + C$$

where A, B, C, D, E, F and Z are adjustable constants.

## Output and control functions

Relay outputs: Outputs for external volume meter, comparators for variables Q and H, and probe failure alarms

Analog outputs: H or Q (0-20, 4-20, 0-5, 0-10, .. mA)

Serial link: Statistical data transmission to PC  
RS 232C for portable PC up to 10 m  
RS485 for desktop PC up to hundreds metres

## Statistical flowmeter functions

The flowmeter is equipped with four groups of statistical registers for recording :

- 5-minute averages of current flow Q;
- total volume and operational time of the flowmeter in hours;
- total volume and operational time of the flowmeter in days; and
- total volume and operational time of the flowmeter in months .

Two-month records are available.

The statistical data can be viewed on a flowmeter display by using a keyboard. For professional use, it is recommended that transmission and statistical data processing are performed on a PC which is provided with SmartMQU Data Acquisition Software.

- Flexible and clever assembling system
- Easy and fast-moving change from compact to remote version
- Innovative and high-power transmitter for every applications
- Robust and resistant cover of sensor and transmitter
- Applications
- Water treatment
- Chemical, food, pharmaceutical industry
- Power, civil engineering

Agriculture

### NOTE:

Because every product is subjected to a development, it can happen that during a period some changes may appear which are not included in the Manual. Possible differences from the description in this Manual can be found by pressing keys on the keyboard in menu. All unclear items should be directly consulted in factory.



## 2. Technical data – Control unit terminal board

### 2.1 Technical conditions

The technical conditions are intended for the set that measures current flow, total volume in open profiles based on the ultrasonic principle of liquid level measurement. The basic data and the information about product, ordering, shipment, installation and maintenance are presented.

#### **Nomenclature:**

*Measuring probe:* consists of an ultrasonic transmitter, receiver and electronic converter that are placed inside housing with the appropriate electrical protection (IP). The reader and the probe are interconnected with a three-core copper wire.

*Controller:* serves for modification and evaluation of the signals coming from the measuring probes and for indication of the values measured; it also includes a real-time clock, output signal generator, comparator and statistics. The controller is designed as a multi-purpose unit with the simultaneous connection of two probes.

#### **The principle of operation:**

The measuring probe is based on the principle of detection of a current level in a profile by means of the reflected ultrasonic waves. The values measured are processed in the microprocessor-based controller.

#### **Operational conditions:**

The measuring probe and the controller are intended for the measurements in the external environment, the units do not require any special building and constructional modifications of the profiles being measured.

The probe is installed above the profile being measured.

Flow and total volume accuracy which is given in the technical conditions includes the error resulting from the level measurement and the data conversion from the curve, **however, this error does not imply any error of measurement profile.**

The measurement quality can be affected by very thick surface foam.

For measurement boxes, it is necessary to select such a size that fully exploits the flowmeter range - it is not permissible that any real flow value for a given box is indicated in the lower part of the scale.

For the Thomson overflow, it is necessary to use the small top angle overflows so that the level measured is as high as possible. For flow near the upper operational limit, the level height must be at least 30 cm, otherwise accuracy is considerably reduced. The unit operates with external power supply of 230 VAC, 50 Hz, 20 VA, and the ultrasonic unit is supplied from the controller.

#### **Installation and operation:**

The final installation, commissioning and programming of the internal (non-user) parameters should be performed by the producer's service team, or by **the workers who have been trained by the producer!**

#### **CAUTION:**

After removing the front cover, the L1, N, PE power supply terminal box is accessible. Only a qualified person can handle the device under such conditions (see Regulations no. 50/1978 Coll. on the Qualification in Electrical Engineering).

Accuracy of the system depends on the correct probe bearing and the setting of operational parameters.

For outside installation and storage with power supply disconnected, air condensation may occur inside electronics. It is necessary to open the unit and to dry it by its placing at room temperature for about 4 hours before the first use. If the unit operates, condensation is avoided by internal heating.



#### **Flowmeter indication:**

Probe label - producer identification, serial number, probe type and IP electrical protection.

Controller label - producer identification, serial number, controller type, IP electrical protection and power supply.

#### **Packaging, transport and delivery:**

If the flowmeter set is ordered without installation, the system is packaged in company corrugated cardboard. The package can be transported by a public haulier, own vehicle, producer, or by mail.

Costs are paid by the customer.

The complete shipment includes -

Measuring probe (one or two)  
Probe clamp - if ordered  
Controller  
Connecting cable - if ordered  
Accompanying technical and commercial documentation

## 2.2. Technical data



### WARNING:

The customer assume personal responsibility for reasonable using of sensor and control unit.

#### Level sensors to 2 m

Level range	0 ÷ 0,4 m or 0 ÷ 1,8 m
Emission angle	10°
Accuracy	0,25 % of range, for reference conditions <sup>1)</sup>
Temperature compensation	internal
Ambient temperature	-20 ÷ 50 °C
Electric protection	IP 68 (NEMA 6)
Power supply	12 ÷ 24 VDC or from control unit / drain < 60 mA
Weight	0,8 kg

#### Level sensors to 6 m

Level range	0 ÷ 5,7 m
Emission angle	14°
Accuracy	0,4 % of range, for reference conditions <sup>1)</sup>
Temperature compensation	internal
Ambient temperature	-20 ÷ 50 °C
Electric protection	IP 68 (NEMA 6)
Power supply	12 ÷ 24 VDC or from control unit / drain < 90 mA
Weight	0,9 kg

Sensor performance	PP (Polypropylen) housing, non-dismountable compact body
Sensor cable	non-rewirable, self-supporting, 4 m lenght

#### MQU 99 or MHU 99 Control unit

Flow measurement accuracy	1,9 % of reading while flow is within 10÷100% of range, for reference conditions <sup>1)</sup> ; this error does <b>not include any error of measurement profile</b> .
Level filter	Digital
Low flow suppression	up to adjusted level limit (Hsupp)
Operating time	run if flowmeter is on power and in measuring mode, while no ultrasonic sensor failure is indicated; double performance at double channel flowmeter
Data logger	2 months capacity (current month + previous month); average 5-minute current flowrates, total volume and operating time by hour/day/month time slices
Real time	Clock and calendar including leap years until 2099; with battery backup
Display	LCD, alphanumeric, 2x16 characters, with backlight
Keyboard	4 keys
Inputs	galvanically separated, for one or two ultrasonic sensors (A, B)
Analog outputs	1 or 2 <b>active</b> galvanically separated outputs, 0(4)÷20 mA / 500 Ω, 0÷5 mA / 2 kΩ or generally selected to maximum 30 mA / 300 Ω, <i>overvoltage protection of III. level</i>
Binary outputs	1 to 4 relays, non-voltage contact, non-inductive load, 250VAC/3A, 30VDC/3A; <b>modes</b> : pulse (according to total flow), comparing (4 submodes), status (echo loss, flood)
Communication output (must be specified)	RS 485 (galv. sep.) or RS 232C, company protocol ELA-1; for current and stored data transmission to PC etc.; on request: data acquisition software Smart MQU for Windows
Power supply	85 ~ 260 VAC/50~60 Hz/10 VA □ 9 ~ 36 VDC/10 W □ 24 VDC/10 W (±10 %)
Fuse	630 mA/F
Cable outlets	3x PG 11
Electric protection	IP 67 (NEMA 5), IP 44 without front cover
Ambient temperature	-20 to +50 °C
Dimensions	180 x Ø 115 mm
Weight	2,6 kg
Housing material	Cast AlSi 10Mg / EN AC-47100
Surface finish	Powered coated (komaxit, anodizing)
Power supply cable	Cu 3 x 1 ÷ 1,5 mm <sup>2</sup>
Sensor connecting cable	Cu 3 x 0,5 ÷ 1 mm <sup>2</sup> , shielded cable recommended for strong noisy environment
Sensor distance	up to 400 m

<sup>1)</sup> Reference conditions: Measured medium: water, waveless, temperature 10-30° C. Environment: streamless air, steady humidity, 18÷25 °C. Sensor exactly situated with proper direction. Level adjustment done at 10% of flow range. Power supply voltage tolerance: ± 2 %. Stabilization after power up: at least 20 minutes.



### WARNING:

For reason of safety and protection health of consumers is necessary to make equipment ground ! (Separate terminal PE on body of equipment).

Converter terminal board, connection of input / output and basic function:

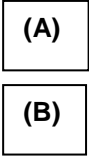
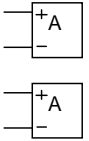
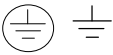
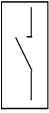
	<b>STANDARD</b>	<b>OPTION</b>	
1 2 3 4 5 6  	brown power supply black function ground grey signal indication LED  cable length 4 m	brown power supply black function ground grey signal indication LED  cable length 4 m	
7 8 9		RS 232 RxD TxD GND cable max. 10 m	RS 485 A B cable max. 500 m
10 11  12 13  14 15	  analog output (A) <b>active output</b> flowrate, level  unwired contact unwired contact	analog output (B) <b>active output</b> flowrate, level	
16 17 L N PE  	<b>85 ~ 260 VAC/10VA</b> do not connect do not connect mains L mains N mains PE	9 ~ 36 VDC/10W do not connect do not connect + 9 ~ 36 V 0 V protective wire	24 VDC/10W + 24 V 0 V do not connect do not connect protective wire
21,22 31,32 41,42 51,52  	relay 1 / <250 VAC, <30 VDC/<3A  totalizer, comparators, failure, etc.	relay 2 / <250 VAC, <30 VDC/<3A relay 3 / <250 VAC, <30 VDC/<3A relay 4 / <250 VAC, <30 VDC/<3A totalizer, comparators, failure, etc.	

**MQU 99-S/C, MHU 99-S/C**

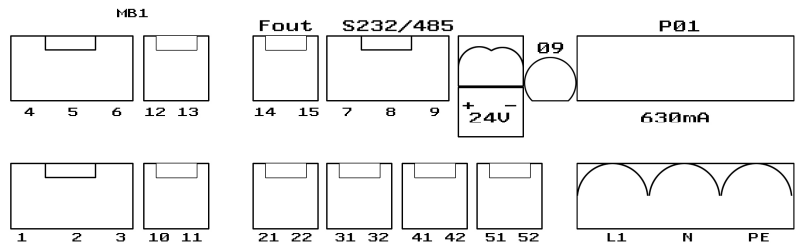
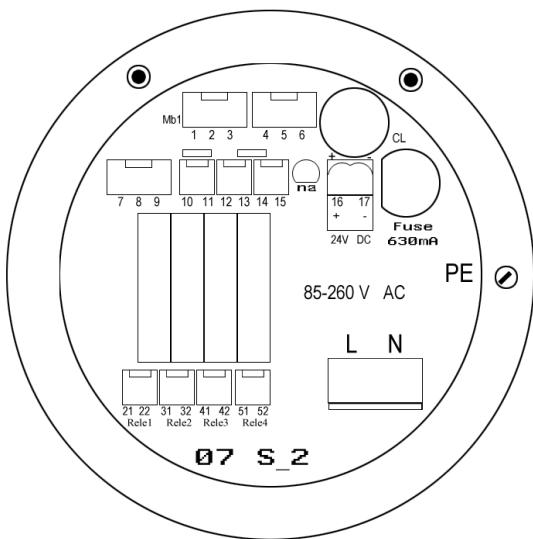

## **MQU 99/MHU 99**

The set for probe installation:  
(only if ordered)  
1 bracket:

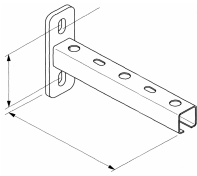

2 dowels, 10 mm – NYLON:

2 combined screws



1 sliding screws for probe fixation:

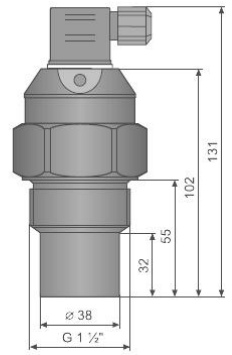
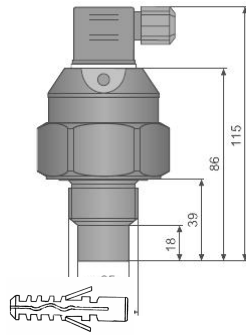
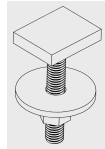

4 M8 nuts, 4 washers and 1 bracket blind plug

### Recommendations for installation:

The DU, series ultrasonic probes can be assembled above the medium being measured by means of Arkon clamps (only if ordered), or hung up on the connecting cable that is delivered as the accessories together with the probes. The cable design makes it possible to suspend the probe along the whole cable length. During the final probe assembly, it is necessary to take into account (especially in a reduced space) the angle of emission of the ultrasonic probes and the dead distance from the level being monitored. It is recommended that the space must be kept free, at least with 10 percent reserve.

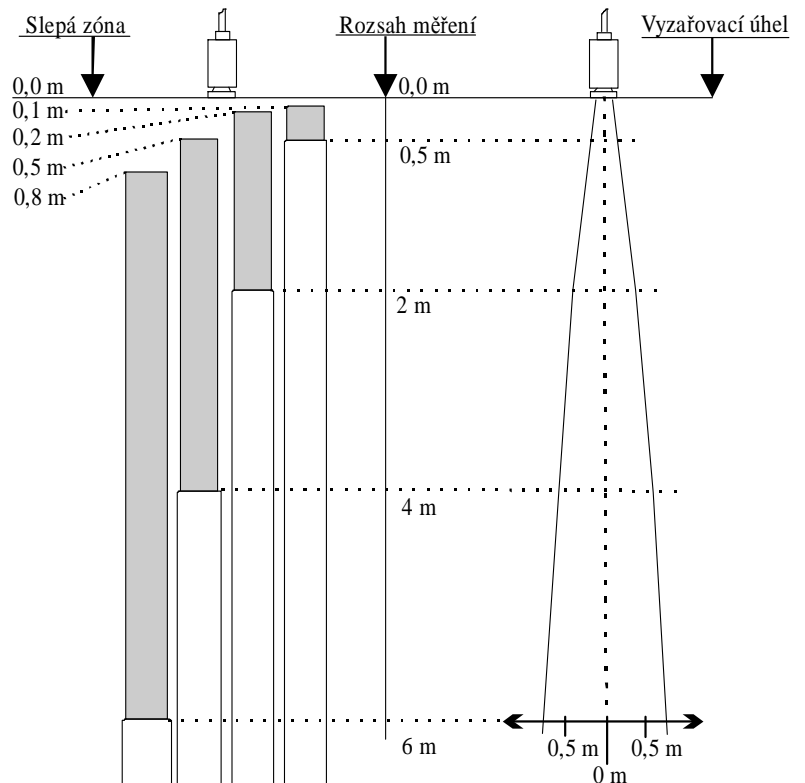

### **Identification and installation of the DU:**

Sensor identification example:

A D U 1,2 (0÷1)

Sensor used with the controller MQU 99 (channel A÷B)

Probe type (compact ultrasonic probe)

Installation distance from the bottom [ m ]

Measurement

range

from

the bottom

[

m

]

Control unit dimensions  
 MQU 99-S/C  
 MHU 99-S/C

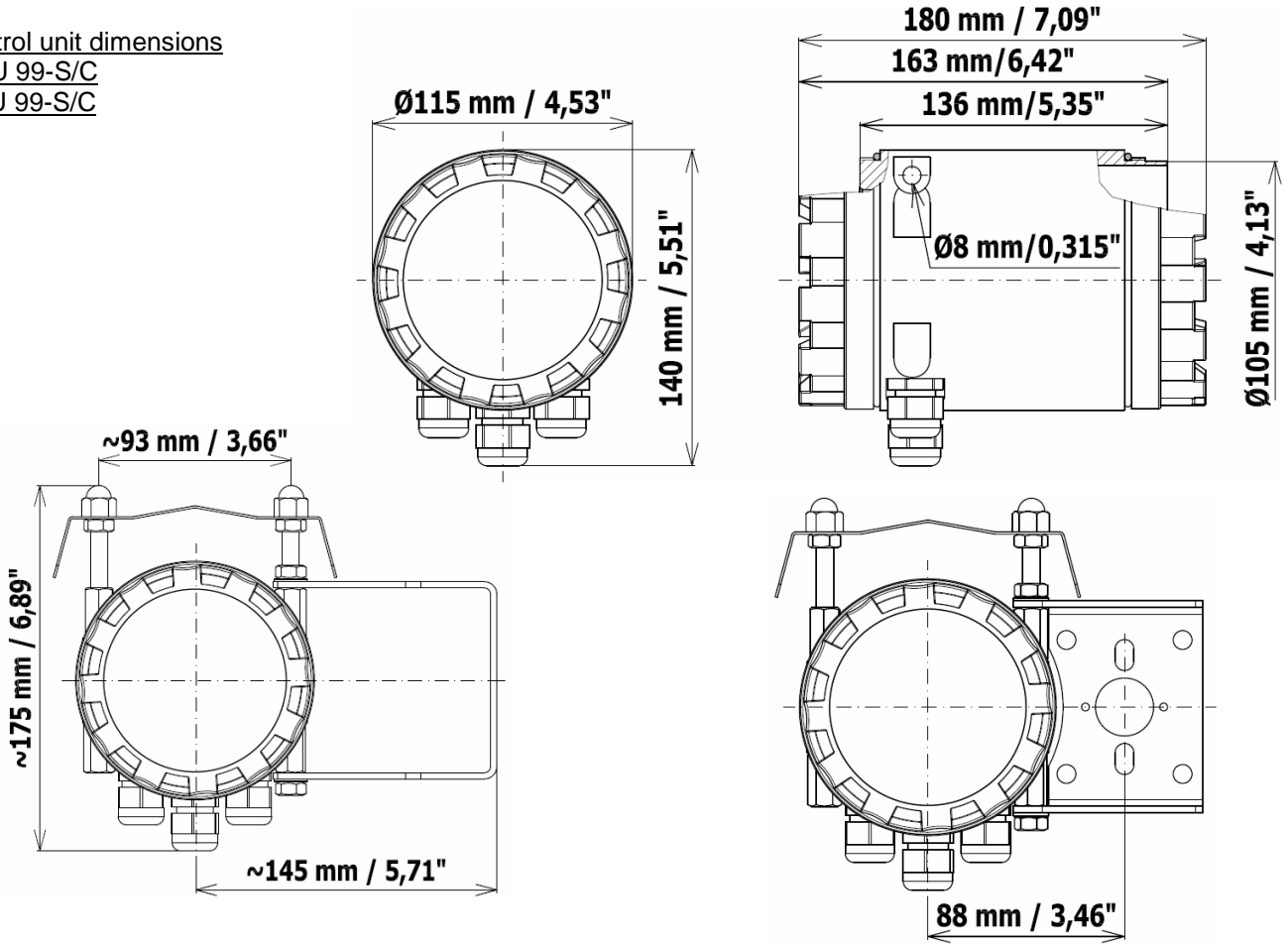

**2,6 kg / 5,73 lb**

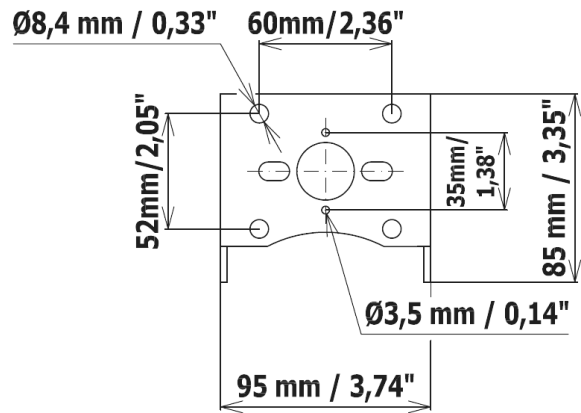
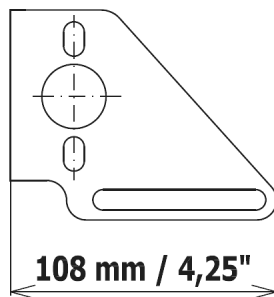

Control unit dimensions  
 MQU 99  
 MHU 99

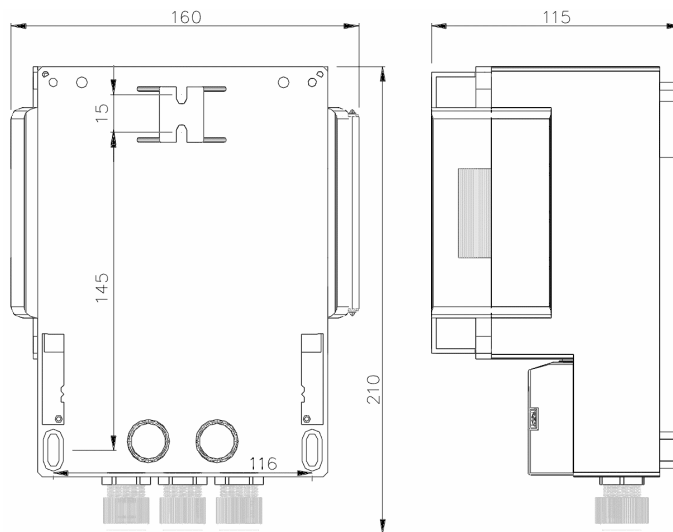

### 3. Mounting kit

Mounting kit

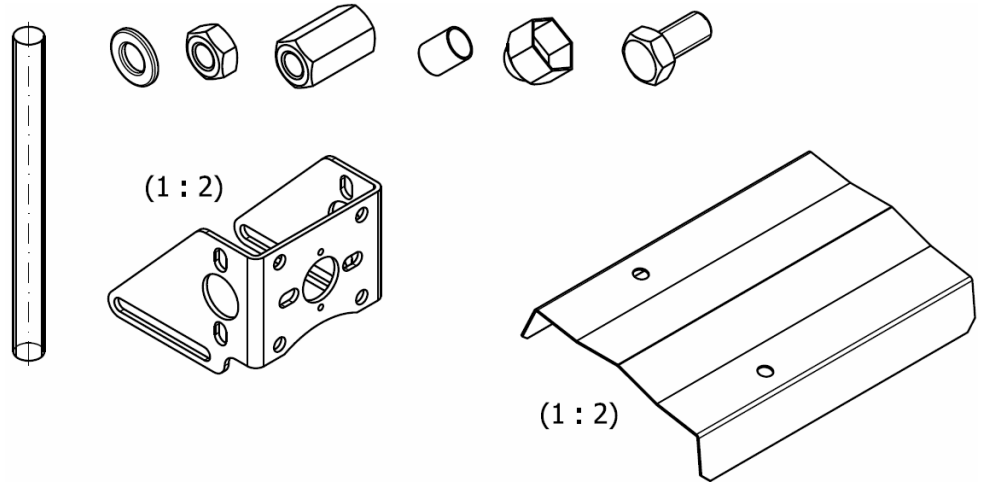

#### 3.1 Possibilities of assembly – compact version

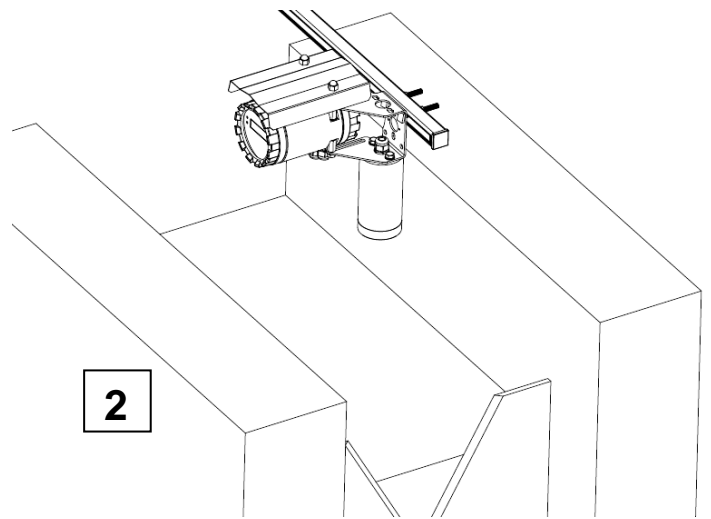
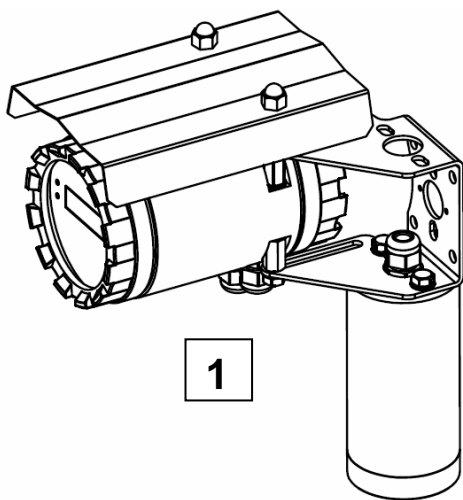

1, 2, 3 – assembly of assembly of sensor in horizontal pipeline

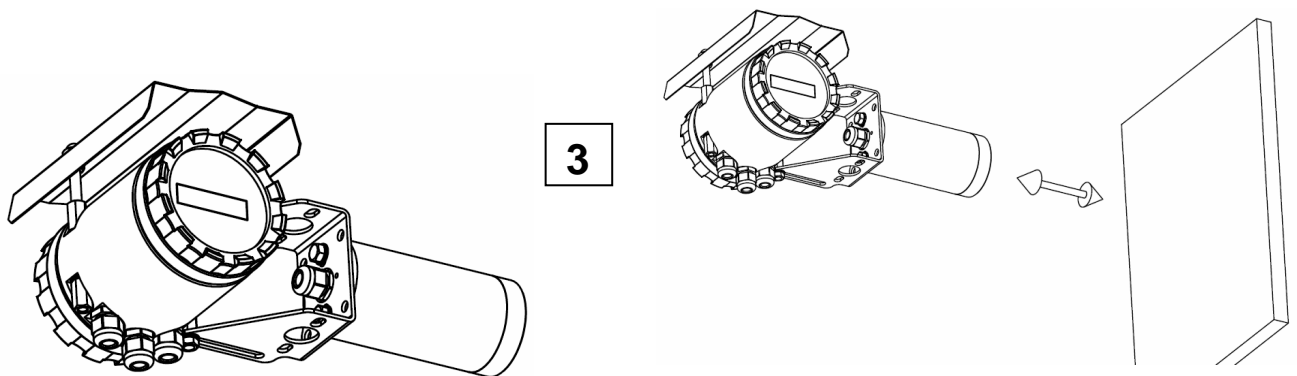

### 3.2 Possibilities of assembly – remote version

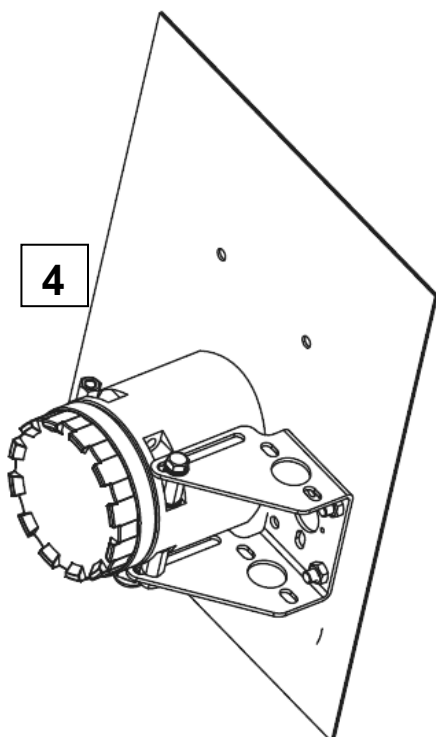

4 – assembly of control unit to the door of switchgear with protection of unit

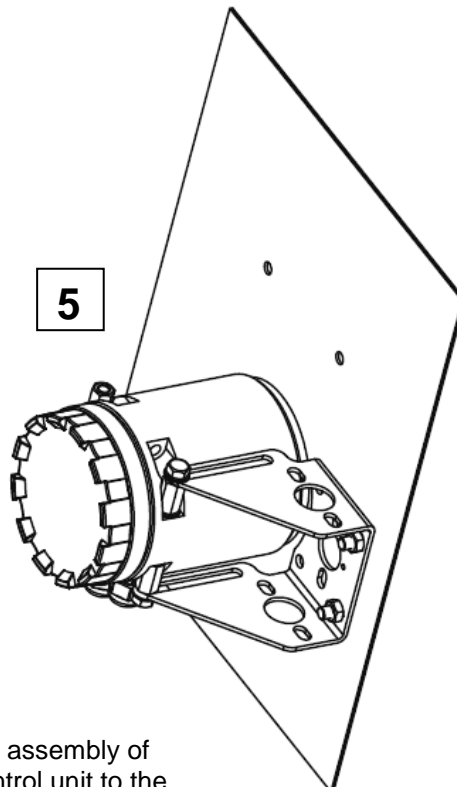

5 – assembly of control unit to the door of switchgear with protection of unit

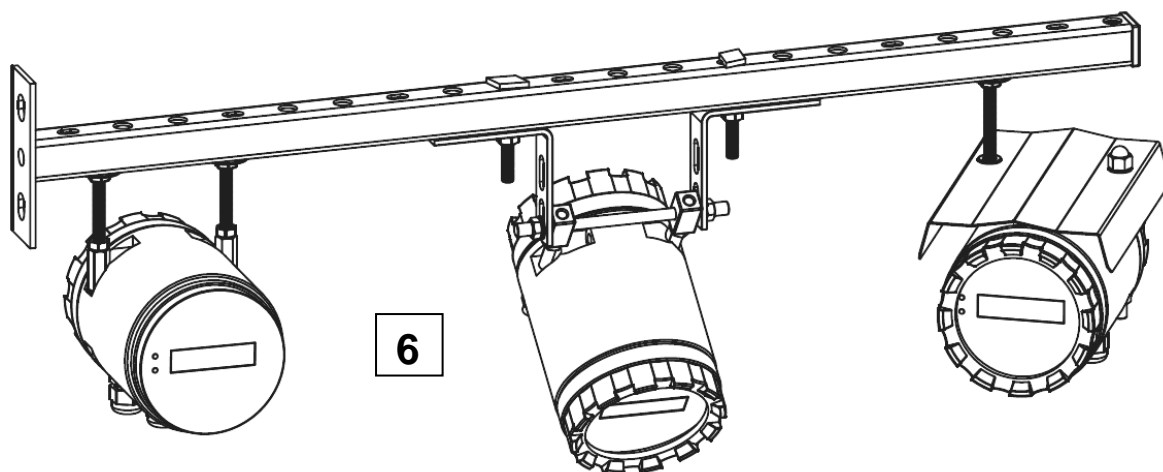

6 – assembly of control unit to the DIN attachment bar or construction of switchgear - multiple overhead and side-by-side application

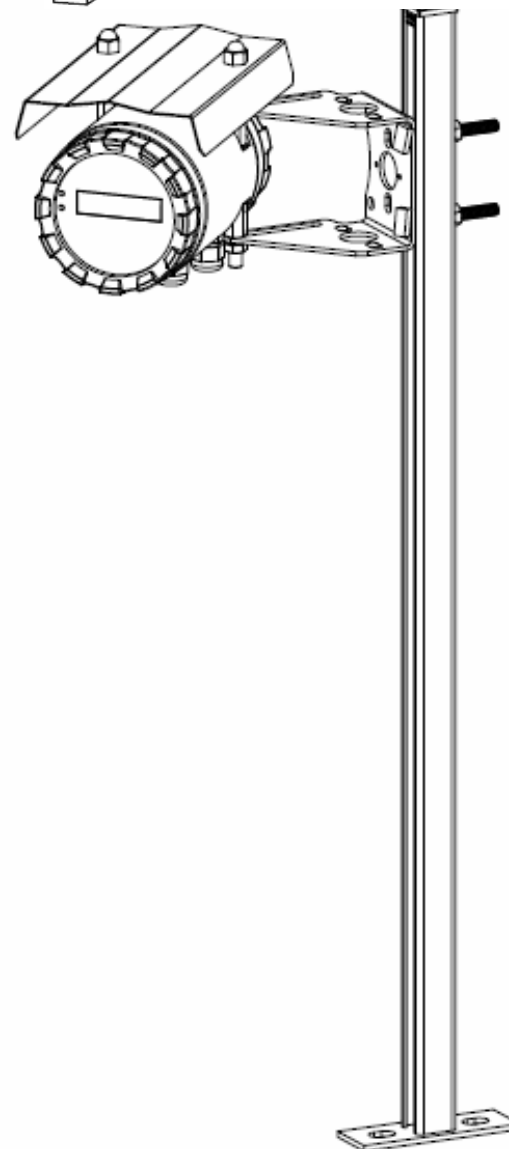
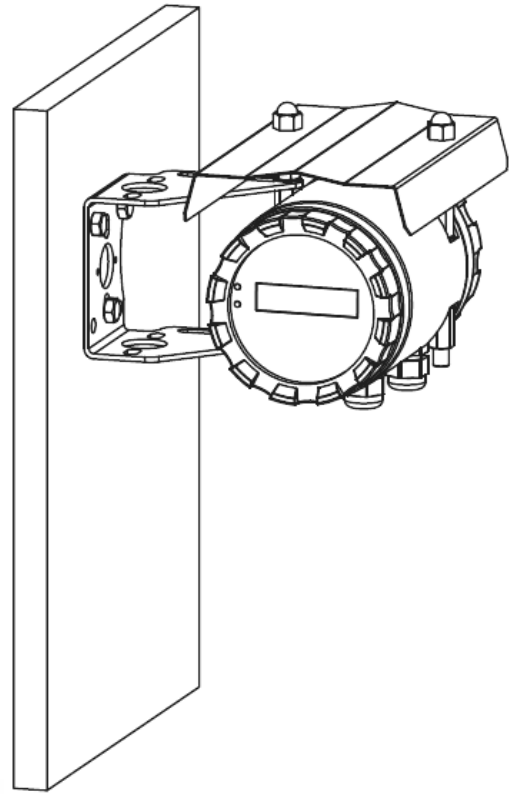
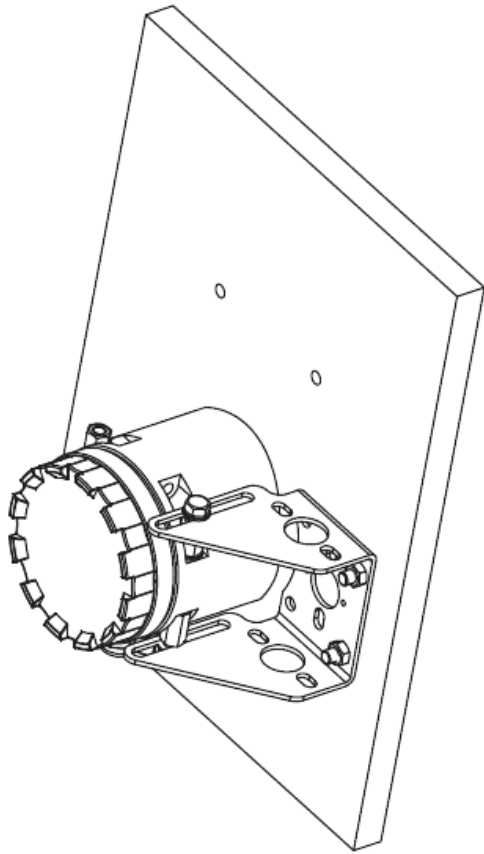

7 – assembly of control unit to the wall - right, left, overhead application and inside unit bracket application

7

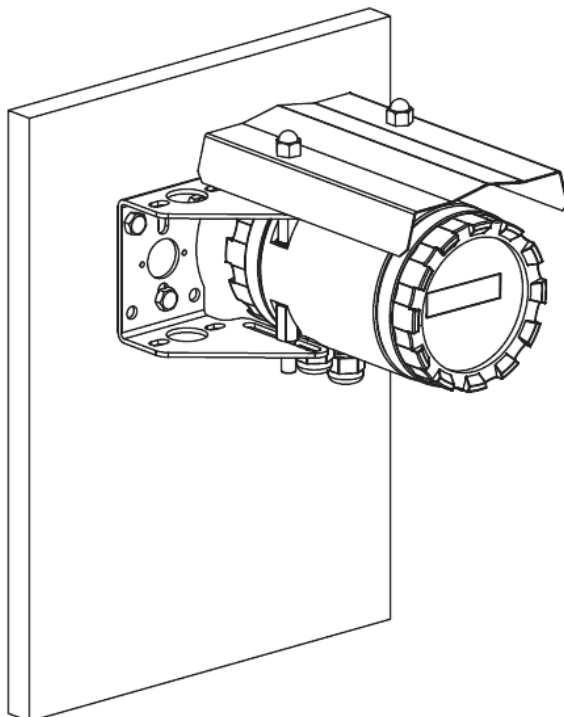

## 4. Instructions for use

### Device keyboard

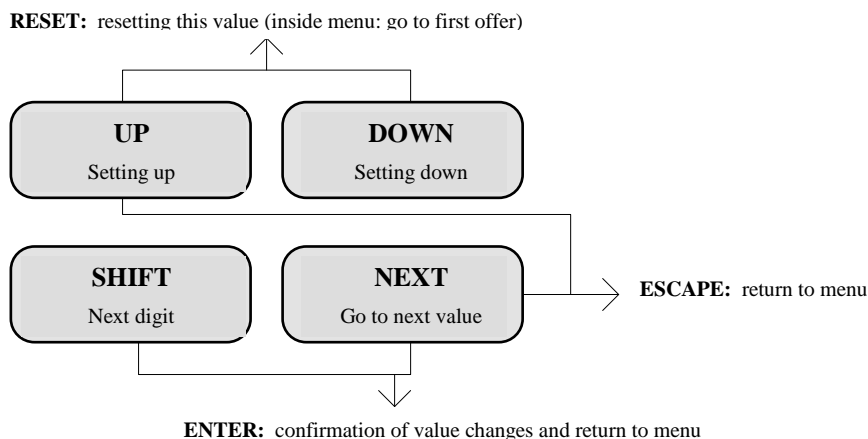

### S+Q menu description - the user mode.

**S + Q** - Displays flow, total volume, level height, operational time, closing/opening relays, sensor failure and failure timer. The items can be selected in the **MAIN** menu, in the **Display** window.

### RUN menu description - the measuring mode with statistical readings.

**Standard view** - transition from the user mode and vice versa.

**Q(t) record** - records of 5-minute flow averages.

**H-statistics** - hourly statistics: total volume and operational time of flowmeter.

**D-statistics** - daily statistics: total volume and operational time of flowmeter.

**M-statistics** - monthly statistics: total volume and operational time of flowmeter.

**Date/time view** - displays the date and time.

**Password check** - password check point – see explanations on page 11.

**Version** - device type and software version.

### MAIN menu description - setting the device.

**Run** - transition to the measuring mode with statistical readings.

**Run / s** - operation in the service mode (intended for installation and testing of the device).

**dH, Hsupp ..** - shift of a level and critical height to suppress flow for individual channels ("a" and "b").

**Filter** - *filtration parameters for individual channels ("a" and "b").*

**Qa=f(Ha)** - selects the formula for the curve, and selects the constants A, B, C, D, E, F and Z in the formula.

**Qb=f(Hb)** - selects the formula for the curve, and selects the constants A, B, C, D, E, F and Z in the formula.

**Display** - time parameters of individual variables (time to display a height, flow and operational time).

**Formats "a"** - format to display individual variables - units and number of significant digits.

**Formats "b"** - format to display individual variables - units and number of significant digits.

**Pulse out "a"** - channel pulse output "a", total volume per 1 pulse, and pulse width.

**Pulse out "b"** - channel pulse output "b", total volume per 1 pulse, and pulse width.

**Comparators** - level and flow comparators with 4 modes, static or pulse operation available.

**Flood check** - *flood indication at outflow according to a level ratio  $H_b / H_a$ .*

**Failure** - *failure delay and hold time.*

**Relays** - assigns the functions for relays 1- 4: channel pulse output "a" or "b", comparator 1 to 4, channel failure "a" or "b", "a + b", and flood.

**Analog out 1** - assigns output variables ( $H_a$ ,  $H_b$ ,  $Q_a$ ,  $Q_b$ ), output range, and nominal current (0-20, 4-20, 0-5, 0-10 mA), current output range extension above the upper limit of nominal current (e.g. up to 24 mA).

**Analog out 2** - assigns output variables ( $H_a$ ,  $H_b$ ,  $Q_a$ ,  $Q_b$ ), output range, nominal current (0-20, 4-20, 0-5, 0-10 mA),

current range extension above the upper limit of nominal current (e.g. up to 24 mA).

**RS 485** - enters transmission line parameters (valid for **RS 232C** standard too).

**Manual output** - manual control of relays 1, 2, 3 and 4, current output - entered directly in mA.

**Date, time** - date and time adjustment: for initialization, press NEXT for 3 seconds.

**Hardware** *parameter intended only for production, and device adjustment.*

**Password** - adjusting the access password for service mode (MAIN menu), if value is 0000 then password is "off"; see explanations on page 11.

**Version** - device type and software version.



### **CAUTION:**

It is recommended that the description in the **MAIN** menu written in italics should not be changed. The parameters are preset taking into account the specified location of measurement box and the type of open box.



### 4.3. Instructions for use – detailed menu description:

**S + Q - user mode:**

After switching on, the device identification and the software version will be indicated over the first three seconds. After elapsing this period, two screens will automatically, or manually by pressing the NEXT key, alter on the display in preset time intervals:

The MQU 99 flowmeter:

1. displays total volume S and current flow Q at the internal counter.
2. displays level height H, the state of four relays (1-closed), failure timer F - sensor failure.

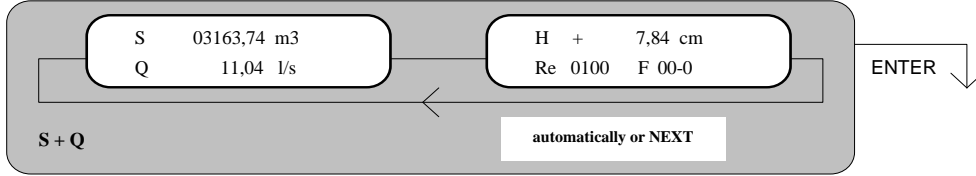

The MQU SMART Series 95, 99 flowmeters and/or if ordered also MQU 99:

1. displays total volume S and current flow Q at the internal counter.
2. displays operational time T, level height H in the profile to be measured.

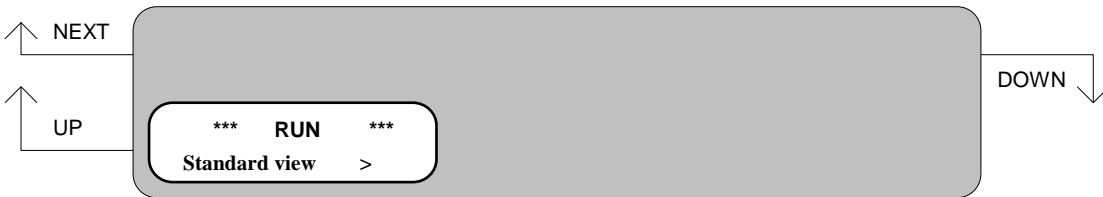

**Standard view - transition from the user mode and vice versa:** The unit proceeds in measurement.

**Q (t) record - records of 5-minute flow averages:** The unit proceeds in measurement.

**Key functions -** UP or DOWN selects 5-minute intervals, UP+DOWN resets hours and minutes, SHIFT + UP or DOWN selects the daily intervals.

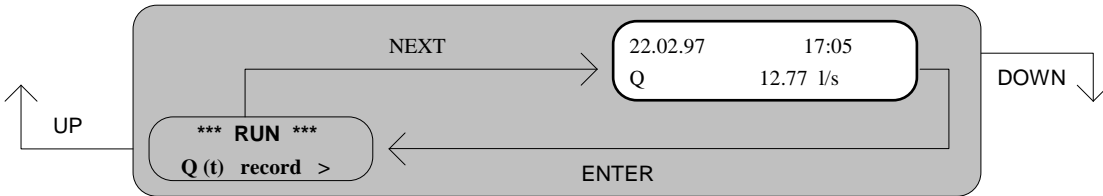

**H-statistics - hourly statistics, total volume and measurement time for every hour:** The unit proceeds in measurement.

**Key function -** UP or DOWN selects the hourly intervals, UP+DOWN resets the clock, SHIFT + UP or DOWN selects the daily intervals.

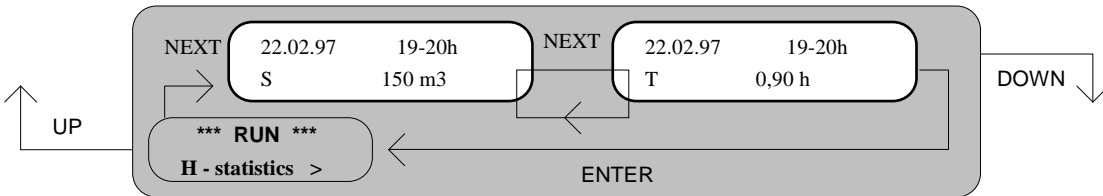

**D-statistics - daily statistics, total volume and measurement time for each day:** The unit proceeds in measurement.

**Key function -** UP or DOWN selects the daily intervals, SHIFT+ UP or DOWN selects the monthly intervals.

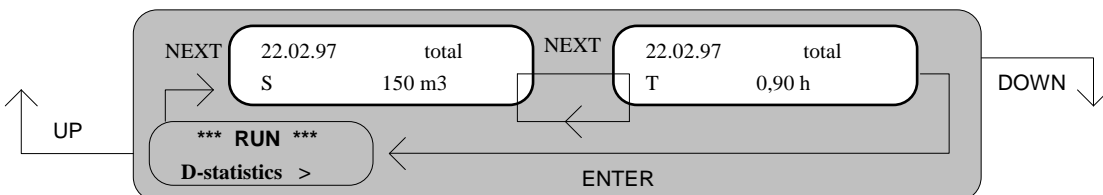

**M-statistics** - monthly statistics, total volume and measurement time for every month: The unit proceeds in measurement.

Key functions - UP or DOWN selects the monthly interval.

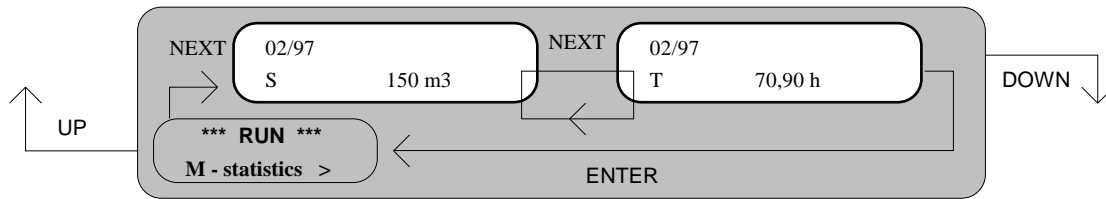

**Date/time view** - displays the date and time: The instrument proceeds in measurement.

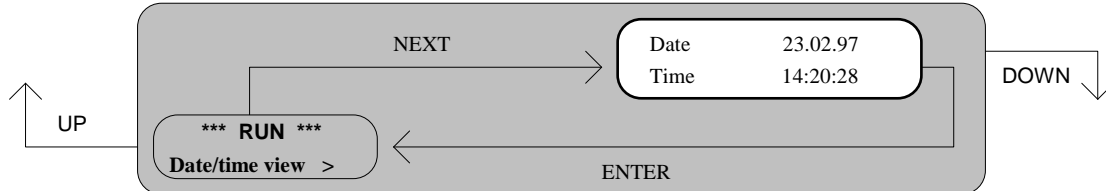

**Password check** – password check point, see exact explanations on page 11 below.

Password check value enables/disables moving from measurement mode (RUN menu) to service mode (MAIN menu). This one is enabled, if Password check value is equal to adjusted password (i.e. MAIN \ Password \ Password).

Default value of adjusted password (factory setting) is usually equal to last three digits of the flowmeter serial number. For example if the serial number is 97145 then default password value is 0145.

Key functions - SHIFT selects other digits (the selected digits are blinking), the UP and DOWN keys select the numbers.

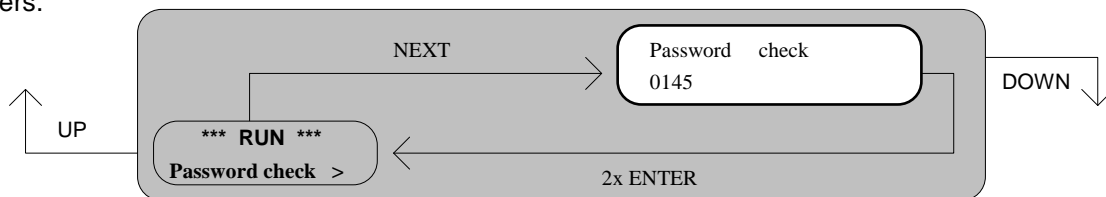

**Version** - device type and software version: The unit proceeds in measurement.

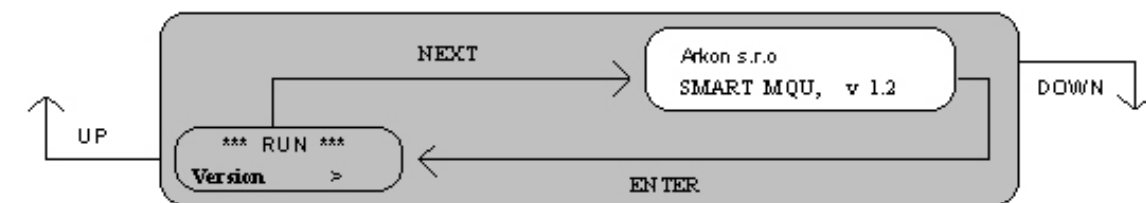

**Two-configuration**

**channel**

**In case of two-probe flowmeter version:**

1. The unit is provided with the second probe.
2. The display of variables in the RUN mode is doubled. First, the "a" channel variables are displayed, e.g. Sa, Ta, then then "b" channel variables are displayed, e.g. Sb, Tb, etc.

## 5. Instruction for adjustment – Detailed menu description

### Run - transition to the measuring mode and vice versa



13

### Run / s - measuring process in the service mode:

Intended for the installation and test of the unit.

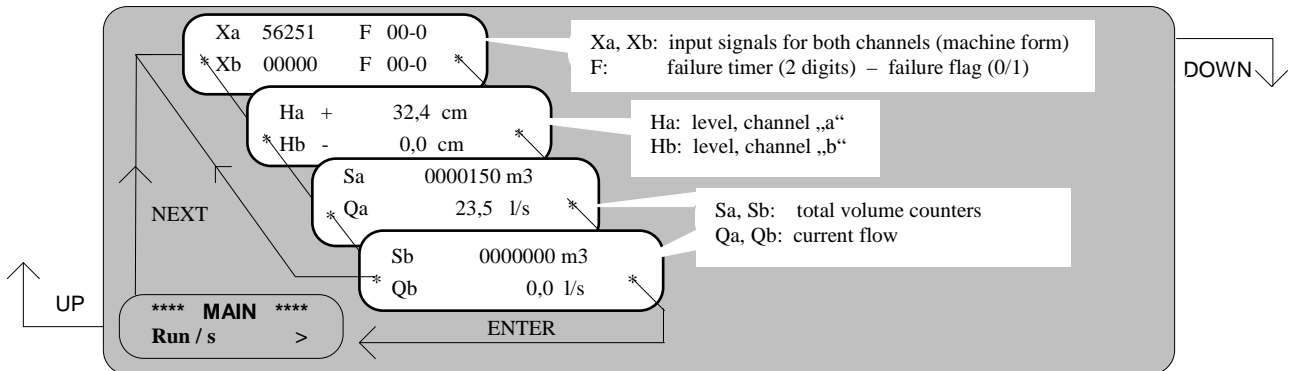

### dH, Hsupp - shifts the level and the critical height for flow suppression of individual channels "a" and "b":

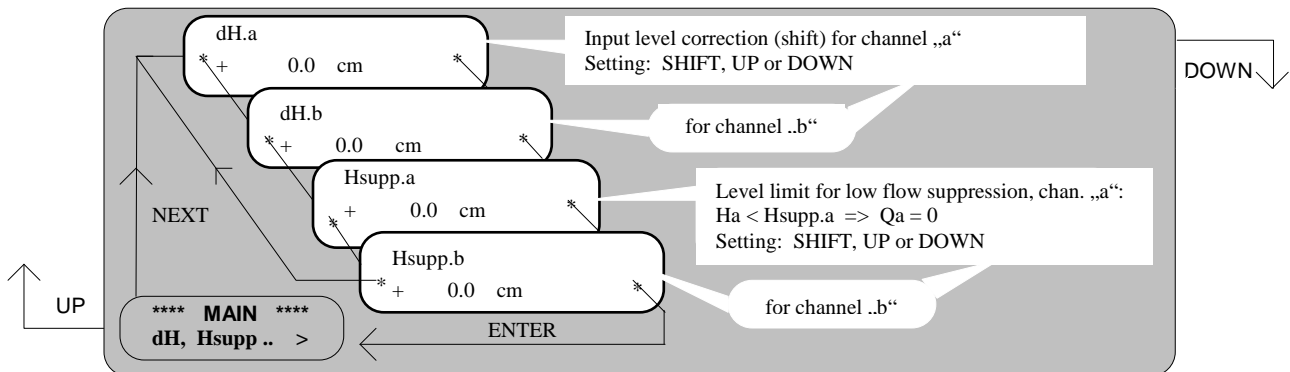

### Filter - filtration parameters for individual channels "a" and "b".

These parameters **must not be changed without consultation with producer!**

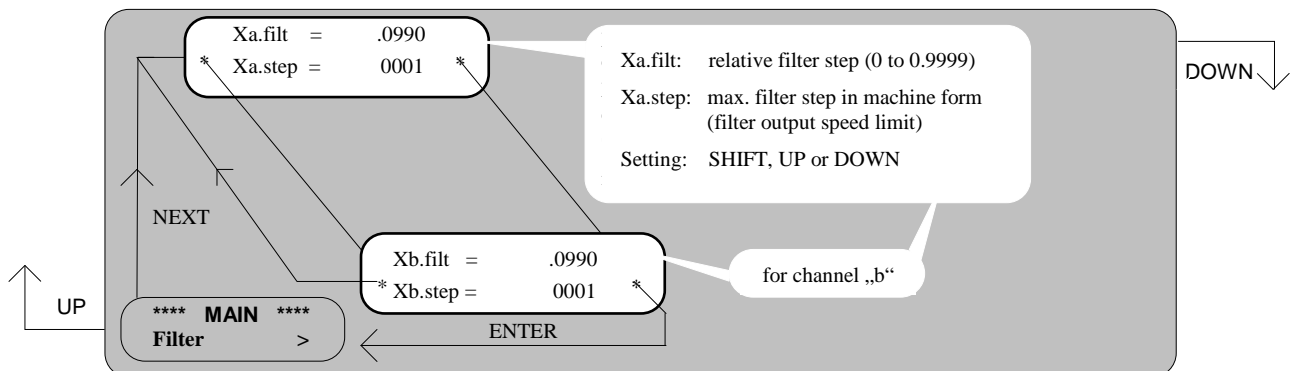

**Qa = f (Ha)** - selects the formula for the curve and sets the constants in the formula:

Example: The curve is given by the following formula  $Q = 1.343 \times h^{2.47}$  [m<sup>3</sup>/sec, m]

**WARNING:** Range for Qa must be set before setting all other values associated with flow or total volume for channel „a“ !!!

**Range for Qa** flow range for channel „a“, see warning above !!!

**Qa function** formula(s) selection, parentheses are equipped with AutoPositive function – negative expression values inside parentheses are automatically converted to zero !!

**Aa** coefficient, from 0.0001 e-02 to 9.9999 e+01 [m<sup>3</sup>/s; m]

**Ba** exponent, from 0.0000 to 3.0000

**Ha => Qa** Qa=f(Ha) calculator (including Hsupp.a) for checking of formula and constants.

For setting all parameters (including Ha for calculator) use SHIFT, UP and DOWN keys.

Example: The curve is given by the following formula  $Q = 1.343 \times (h + 0.001)^{2.47}$  [m<sup>3</sup>/sec, m]

**WARNING:** Range for Qa must be set before setting all other values associated with flow or total volume for channel „a“ !!!

**Range for Qa** flow range for channel „a“, see warning above !!!

**Qa function** formula(s) selection; parentheses are equipped with AutoPositive function – negative expression values inside parentheses are automatically converted to zero !!

**Aa** coefficient, from 0.0001 e-02 to 9.9999 e+01 [m<sup>3</sup>/s; m]

**Ba** exponent, from 0.0000 to 3.0000

**Ca, Da** additive constants, with sign (units according to MAIN \ Format „a“)

**Ha => Qa** Qa=f(Ha) calculator (including Hsupp.a) for checking of formula and constants.

**Example:** The combined profile to be measured has the following curve

$$- h < 0.56 \text{ m: } Q = 0.1989 \times h^{1.564}$$

$$- h > 0.56 \text{ m: } Q = 0.1989 \times h^{1.564} + 2.4 \times (h - 0.56)^{1.5}$$

If the parenthesis are considered as the limitation function of non-negative values (the negative values are replaced by zero, which SMART performs automatically), the curve can be given by the only formula:

$$Q = 0.1989 \times h^{1.564} + 2.4 \times (h - 0.56)^{1.5} \quad [\text{m}^3/\text{s}, \text{m}]$$

**WARNING:** Range for Qa must be set before setting all other values associated with flow or total volume for channel „a“ !!!

**Range for Qa** flow range for channel „a“, see warning above !!!

**Qa function** formula(s) selection; parentheses are equipped with AutoPositive function – negative expression values inside parentheses are automatically converted to zero !!

**Aa, Ea** coefficients, from 0.0001 e-02 to 9.9999 e+01 [m3/s; m]

**Ba, Fa** exponents, from 0.0000 to 3.0000

**Za** additive constant, with sign (unit according to MAIN \ Format „a“)

**Ha => Qa** Qa=f(Ha) calculator (including Hsupp.a) for checking of formula and constants.

For setting all parameters (including Ha for calculator) use SHIFT, UP and DOWN keys.

**Example:** The curve  $Q = A \times (h+D)^B + C + E \times (h+Z)^F$

Selection of the formula  $Ax(h+D)^B+C+Ex \dots$  and substitution of the constants, and scrolling over the menu as in the previous examples.

**Example:** The curve  $Q = \text{section } 1) A \times h^B \text{ section } 2) E \times (h+Z)^F$

Definition by means of two formulae, where the first formula is valid for values  $H_a$  lower than the section limit, while the other formula is valid for values  $H_a$  higher than the section limit.

Qa section limit  
+ 10.0 cm

Level limit for switching between formulas.  
Setting: SHIFT, UP or DOWN.

Interpretation: **if**  $H_a < Qa\_section\_limit$  **then**  $Q_a$  is calculated by the first formula **else** by the second formula

**Example:** The curve  $Q = \text{section } 1) A \times (h+D)^B + C \text{ section } 2) E \times (h+Z)^F$

Selection of the formula-  $A \times (h+D)^B+C, E \dots$  substitution of the constants, and scrolling over the menu as in the previous example. From the view of access to adjustment, "Qa=f(Ha)", the unit is configured in factory to one of three states:

\*\*\*\* MAIN \*\*\*\*  
Qa = f(Ha) > Read and write configuration.

\*\*\*\* MAIN \*\*\*\*  
Qa = f(Ha) r Read only configuration.

\*\*\*\* MAIN \*\*\*\*  
Qa = f(Ha) # No access configuration.

**Qa = f (Hb)** -selects the formula for the curve and sets the constants in the formula:

The setting is carried out in the same way as for the channel "a". The producer can also deny any access to writing/reading the data.

**Display** - time parameters to display individual variables (time to display height, flow and operational time):

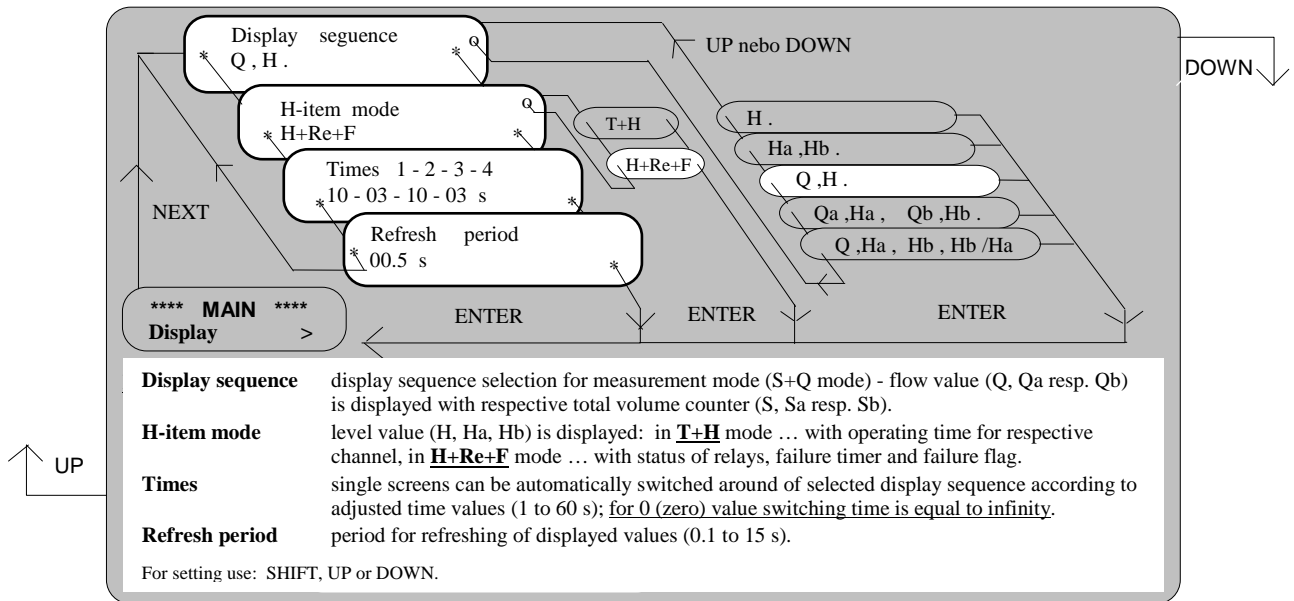

**Example:** The block diagram describes the display behaviour in the S + Q mode for the above-described setting after connection to power.

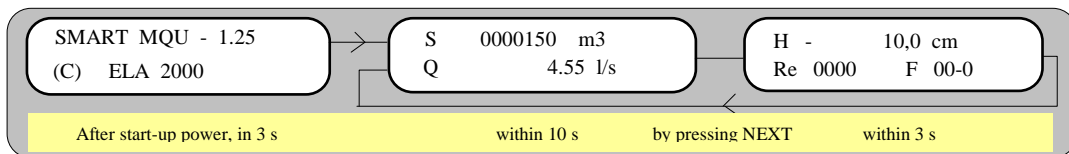

**Formats "a"** - the format displays the individual variables, units and the number of significant digits:

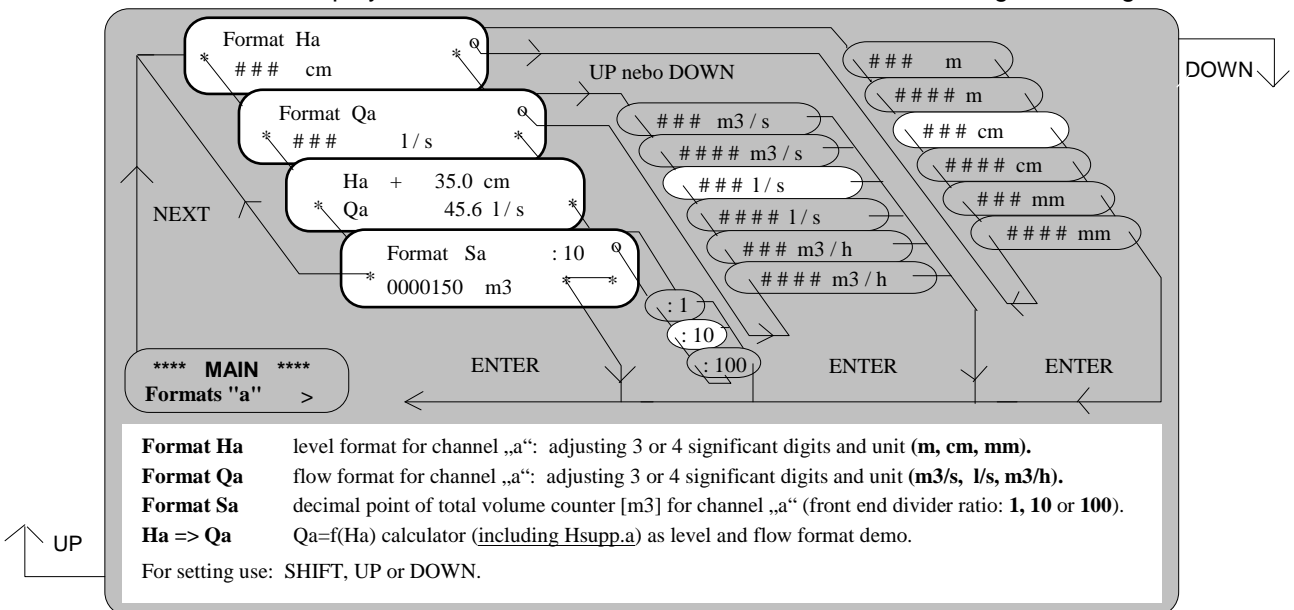

**Formats "b"** - the format displays the individual variables, units and the number of significant digits: The setting is carried out in the same way as for the channel "a".

**Pulse out "a" - channel "a" pulse output, total volume per 1 pulse, pulse width:**

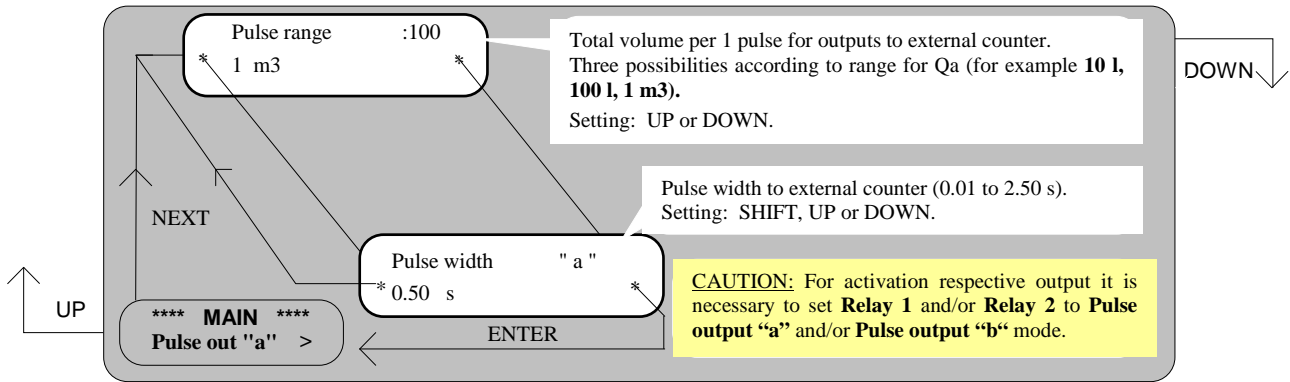

**Pulse out " b" - channel "b" pulse output, total volume per 1 pulse, pulse width:**

The setting is carried out in the same way as for the channel "a".

**Comparators –level and flow comparators with 4 modes, static and pulse operation available:**

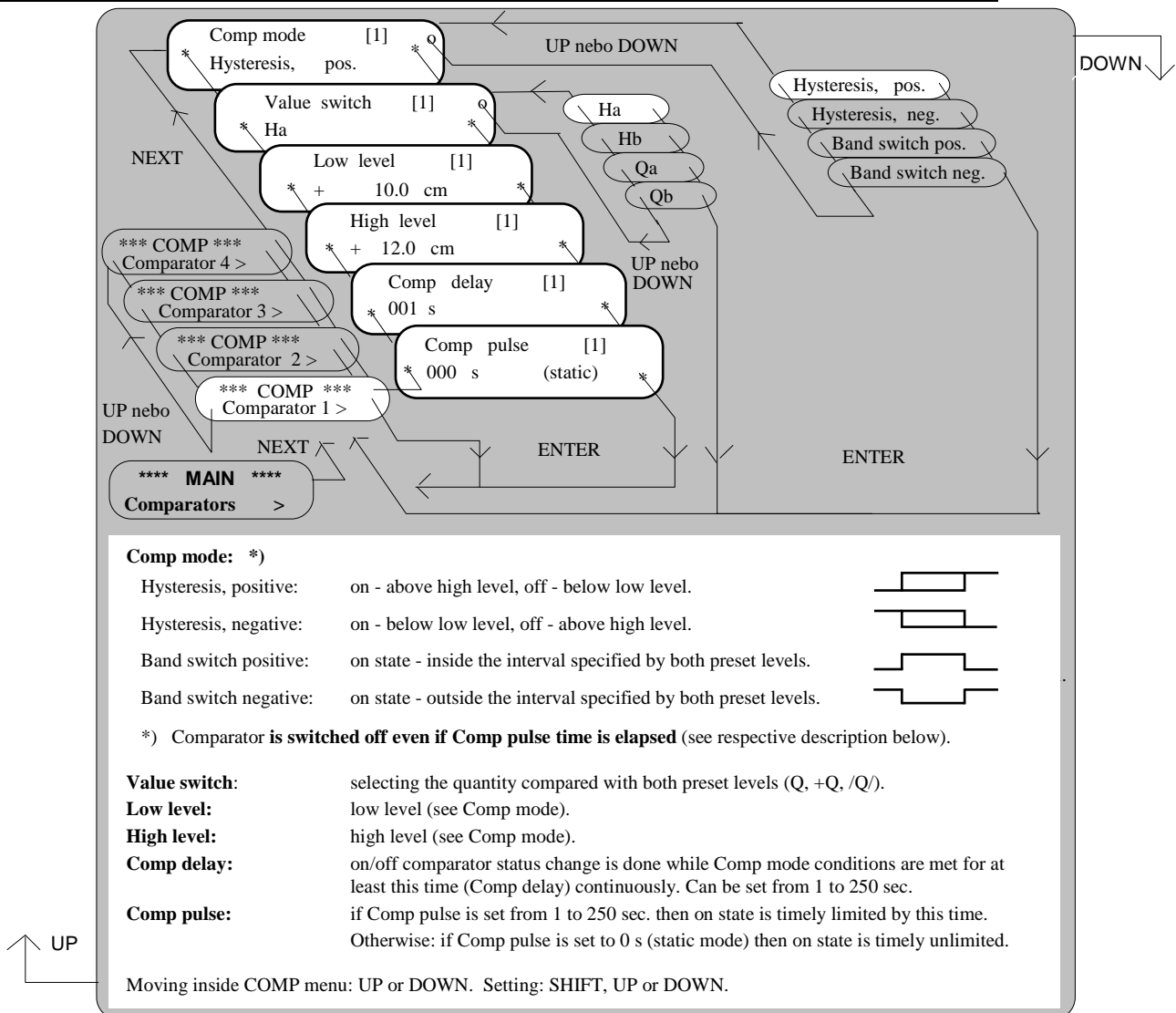

**CAUTION:** In addition to the setting of the variables shown in this chart, it is necessary to set the relay to the "Comparator 1 to 4" mode. Otherwise the comparator has no effect on flowmeter outputs.

**Flood check - checking of flood status at flume outlet according to the Hb/Ha level ratio:**

This function is only used at the unit which is provided with the second sensor for checking the outlet level (Hb).

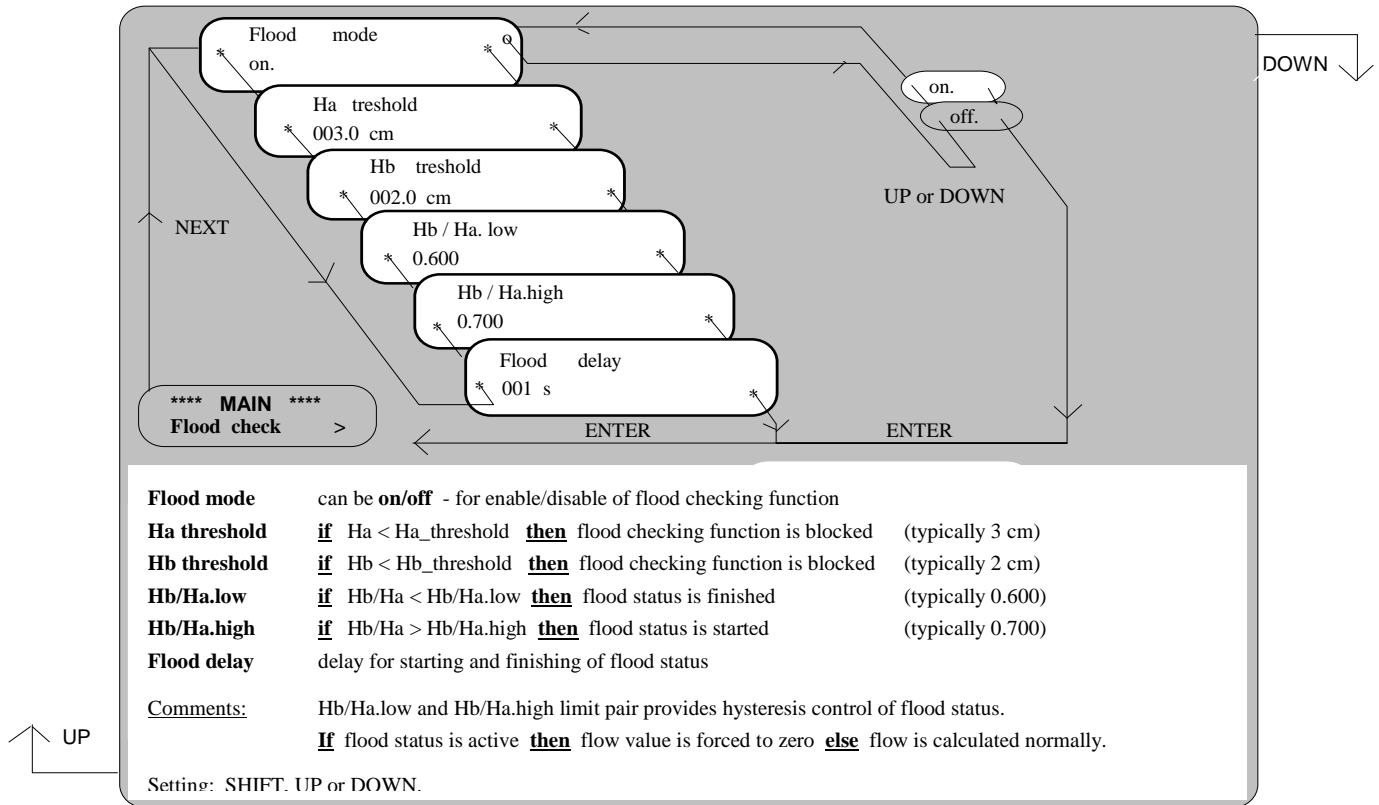

**Failure - failure delay and failure hold time:**

These values are valid for both channels together.

If channel "a" or/and channel "b" sensor sends to control unit bad input values (points), then failure status on respective channel(s) occurs. After restoration the normal input values failure status of channel(s) is finished. During failure status on respective channel(s) level value and flow value are forced to zero.

Failure status control algorithm is dependent of following parameters:

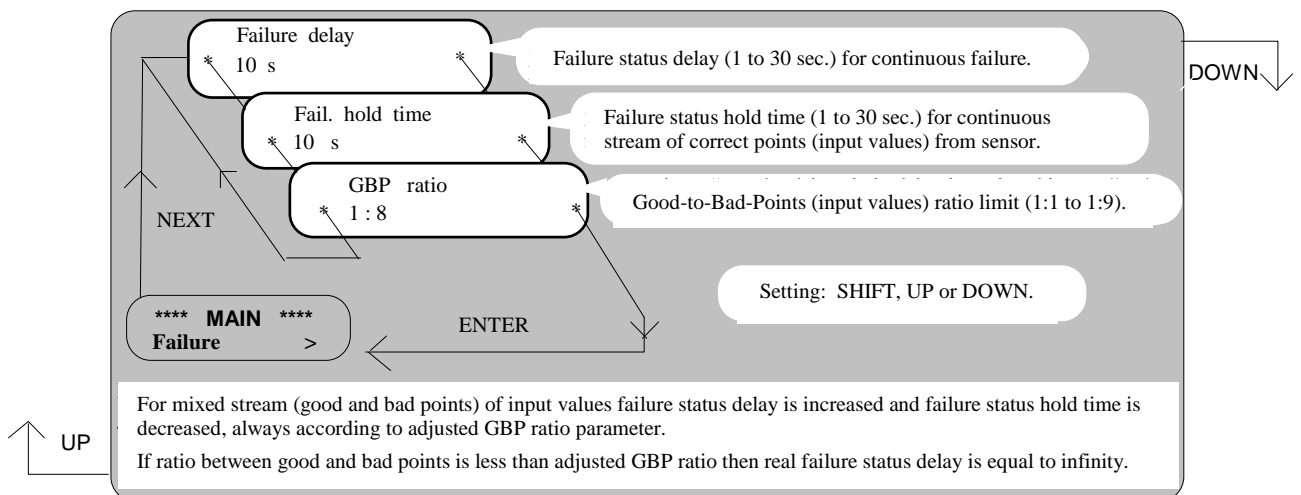

**Relays** - assigns the functions for the relays 1 to 4, pulse output "a" and "b", comparators 1- 4, channel failure "a", "b", "a+b" and flood:

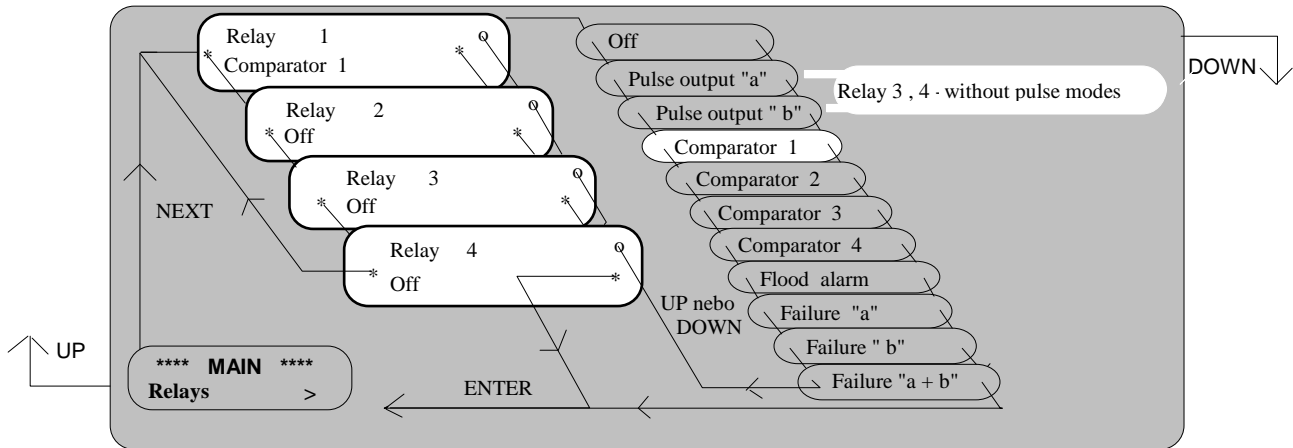

**Analog out 1** - assigns output values, output range, nominal current and current range extension:

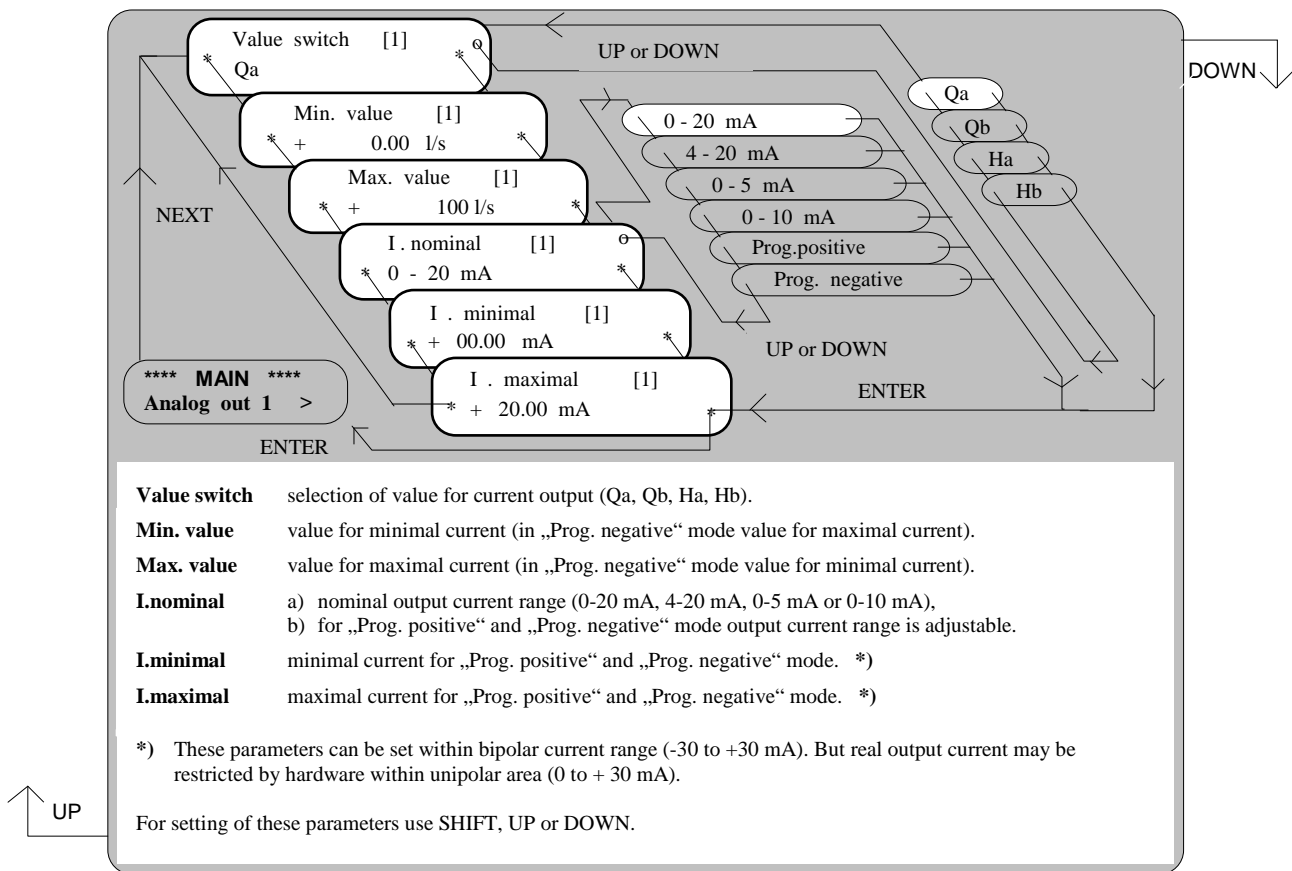

**Analog out 2** - assigns output values, output range, nominal current, and current range extension:

The setting is carried out in the same way as for Analog out 1.

**RS 485 - parameters of communication port in ELA-1 format (valid for RS 232C standard too)**

**Device address** Device identification address (0 to 255). In order to have correct communication and data acquisition process **device address must be unique for any communication standard !!**

**Baud rate** Typical and recommended value is 9600 Bd.

**R/T timeout** Block synchronization limit (0 to 70 ms). Recommended value for Baud rate of 9600 Bd is 10 ms.

Other screens are intended for producer service purposes. For setting use SHIFT, UP or DOWN keys.

**Manual output - manual control of relays 1, 2, 3 and 4, current output - entered directly in mA:**

Manual control of all relays („0“ .. off, „1“ .. on).

Manual control of output current (-30 to +30 mA). This current output range can be restricted by hardware.

The same.

Setting: SHIFT, UP or DOWN.

**Date, time - sets the date and time:**

In order to stop date/time and open the date/time setting press NEXT again for at least 3 sec.

Set date/time value using SHIFT, UP or DOWN keys.

Press NEXT, then date/time will start again.

**Hardware - the parameter intended only for adjustment in factory:**

**Password – controls an access into service mode (MAIN menu), for details see page 11:**

If Password is equal to 0000 then service mode (MAIN menu) can be freely entered from menu RUN.

Factory setting is usually equal to last three digits of the flowmeter serial number. For example if the serial number is 97145 then default password value is 0145.

**Version – device type and software version.**

## 6. Example

The U 0.7 (0 - 0.4 ) ultrasonic probe, which is intended for the installation above the measurement profile at a distance of 0.7 m from the bottom, was assembled at a distance of 0.65 m from the bottom. The display shows a level height of + 5 cm for zero level. Hence, it is necessary to correlate the monitoring of level height for the "a" channel in the following way:

**dH, Hsupp** - shift of the level and the critical height for flow suppression in the individual channels "a" and "b":

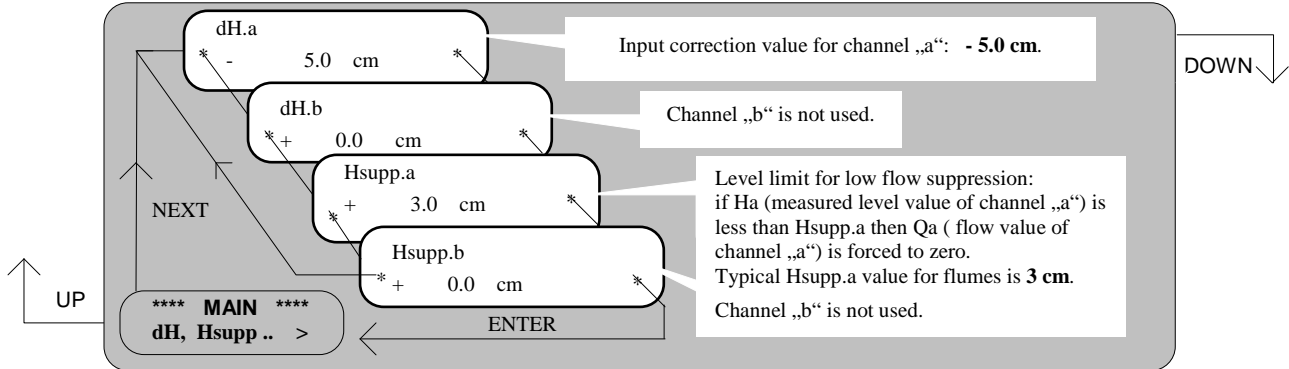

After this correlation, the flowmeter will show the zero level height  $H_a$  for zero flow.

This correlation must be done after sufficient flowmeter stabilization, i.e. within 20 to 30 minutes after the first switching on provided that the measurement box is constructed in both longitudinal and lateral direction in the absolute plane. In case of an unsuitable construction, these inaccuracies must be taken into account during correlation.

### Example:

For flows above 100 litres/sec, it is necessary to close the relay at the SMART unit. Follow the instructions:

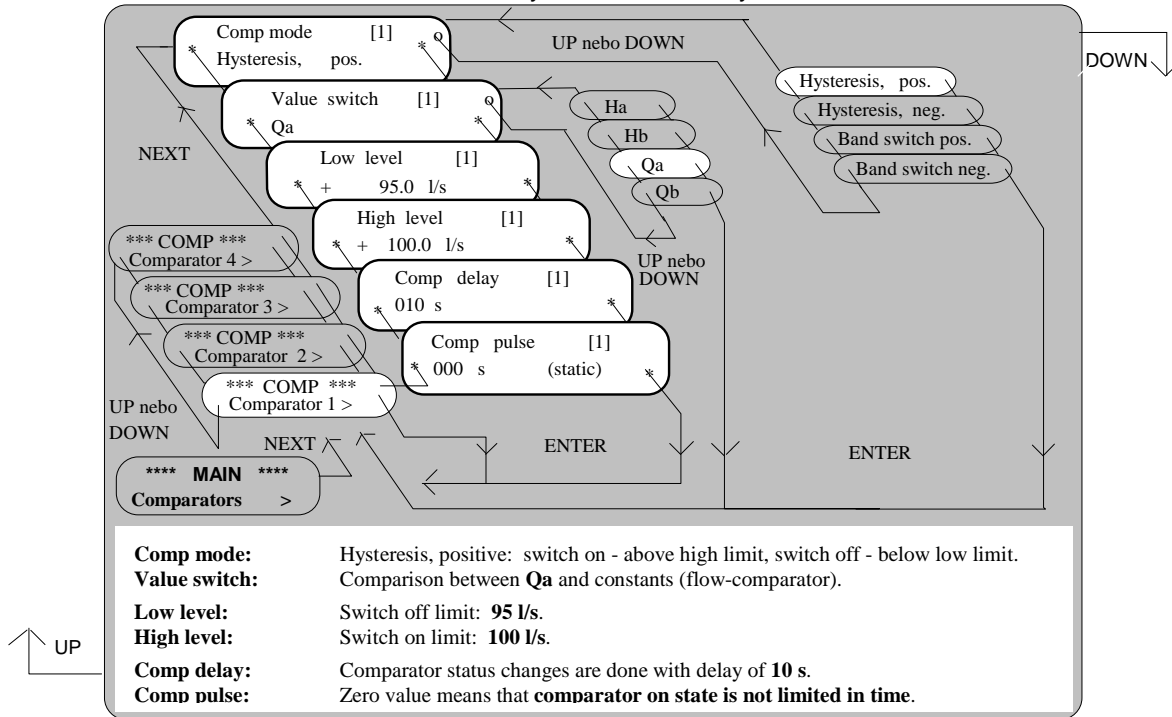

A relay from the **Relays** menu should be assigned to the adjusted comparator in the following way: Relay 1 to Comparator 1.

The adjusted comparator including the assigned relay 1 will close if current flow exceeds 100 litres/sec with a preset delay of 10 sec. The closed relay 1 will open if flow reduces below 95 litres/sec with a delay of 10 sec. The other correlations and adjustments of the SMART unit can be done in similar way according to the instructions for use.



### CAUTION:

Troubleshooting in the electrical system can be performed only by a qualified person (see Regulations No. 50/1978 Coll. on The Qualification in Electrical Engineering).

## 7. Smart MQU – Data acquisition software

Smart MQU Data Acquisition Software provides following support for MQU 99 ultrasonic flowmeters for measuring profiles (1 or 2 channels per flowmeter):

- Online monitoring** ► of status and main measured values (current flow, total volume counters and operating time of both channels, ...) of connected flowmeters, see **Transfer** panel
- Statistic data transfer** ► from flowmeters to PC database file, see **Transfer** panel
- Statistic data outputs** ► from PC database file to PC display, printer or to exporting CSV files, see **Statistics** and **Flow** panels

### 7.1. Transfer panel

#### Statistic data transfer

**Transfer** panel serves for statistic data transfer from flowmeters statistics memory to PC database file, which is accessed by **Statistics** and **Flow** panels for displaying, printing and exporting process.

#### Online monitoring

Other function of this panel is online monitoring of status indicators and main measured values (for one or two flowmeter channels):

- **Measuring:** “Measuring process active” indicator
- **Fail A or B:** “Sensor failure at respective channel” indicator
- **Ha, Hb:** Level in this time in **cm**
- **Qa, Qb:** Flow in this time, in **l/s**
- **Sa, Sb:** Total flow volume in **m<sup>3</sup>**
- **Ta, Tb:** Operating time in **h** (hours)
- **Relay 1 to 4:** Relay status indicators

### 7.2. Statistic panel

This panel serves for managing the output functions of following statistic values (for selected flowmeter and its channel **A** or **B**):

- **Measuring [h]** operating time (for tables only)
- **S [m<sup>3</sup>]** total flow volume

Output function are started by following keys:

- **Show** Displaying of graphs and tables
- **Print** Printing of graphs and tables
- **Export** Exporting to CSV format files (for EXCEL or other software)

Graphs, tables and exporting files are organized in time slices, according to time slice switch alternatives:

#### **Month / Day / Hour.**

Every table line includes day of week, date, time and two above listed values for respective time slice. Below any output table column sum values are added.

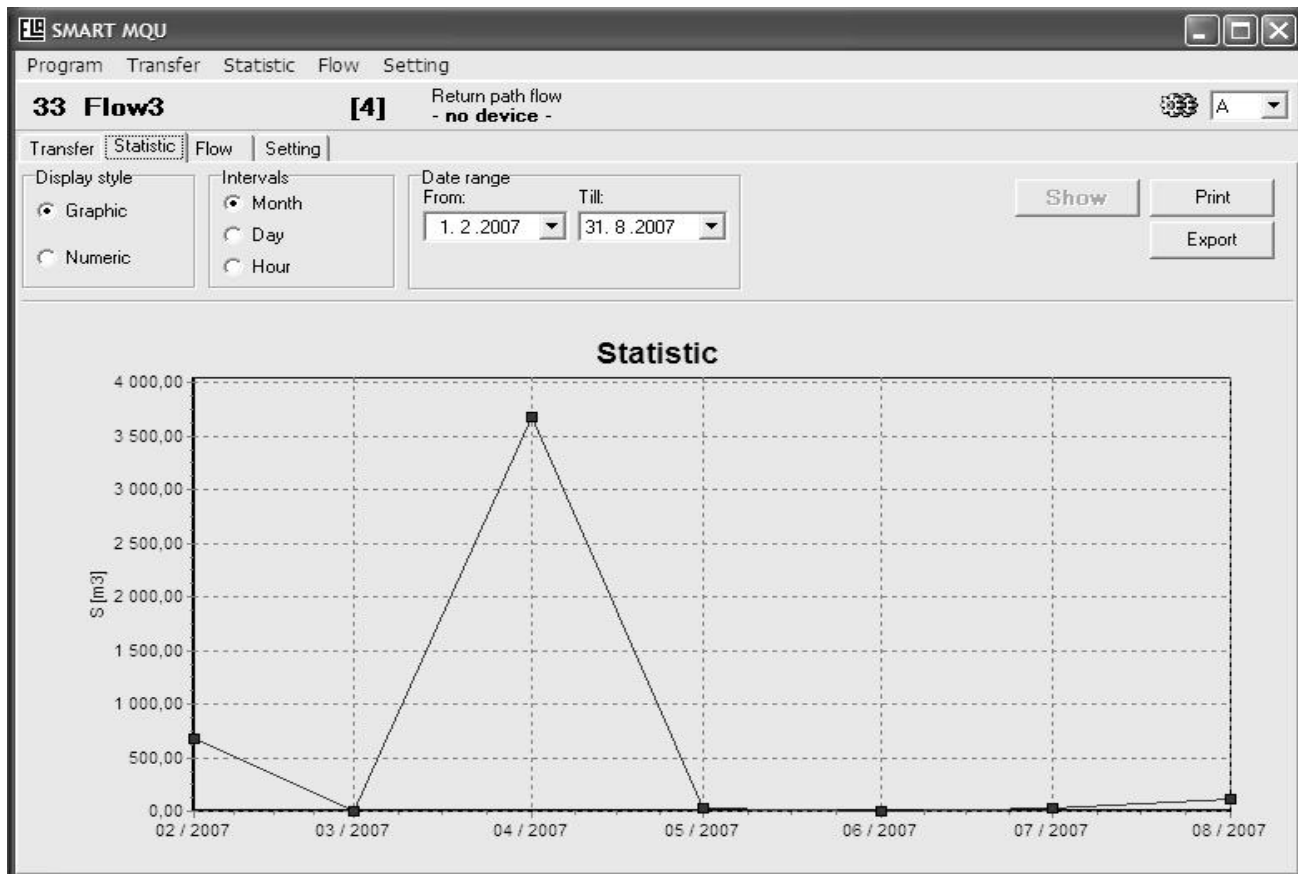

### 7.3 Flow panel

This panel serves for managing the output functions about Q(t) record (exactly: 5-minute arithmetic mean values of flow). Output functions and keys are the same as at Statistics panel.

#### Recommended PC configuration (at least):

- PC Pentium 133, 64 MB RAM, 100 MB hard disc free space
- Windows 98 SE operating system
- Internet Explorer 5.5
- Communication port: COM (RS 232C or RS 485) port or USB (1.1 or 2.0) port
- Virtual port driver, while using USB port
- Respective connecting cable and/or line converter for correct connection between PC communication port and flowmeter interface, which may be of RS 232C or RS 485 standard - see Smart MQU User Manual for details about converter type and settings

## 7.4 Troubleshooting - List of symptoms, causes and remedies during operation

SYMPTOM	CAUSE	REMEDY										
Blind display - operation signalling sensor does not light - "A" (red), and/or "B" (green)	Power supply not connected	Check power supply source and line fuse inside the unit, contact the producer's service*										
Device does not measure - level height is 0, flow 0, signalling of failure "F" (page 16 in the Manual) on the display, the operation signalling sensor does not light - "A" (red), and/or "B" (green)	1) Sensor not connected 2) Level monitored out of the probe range 3) Thick foam layer at the measured level 4) Deposit on the sensor face after flooding 5) Sensor failure	1) Check the sensor - reader connection 2) Check the correct sensor position from the bottom, an obstacle under the sensor 3) Locate a standard foam separator upstream the point being monitored 4) Clean the sensor 5) Restart the device, and contact the producer's service*										
Improper reading on the display, message "Error"	1) Strong line voltage interference - not complying with the CZ standards, 2) 230 VAC power supply out of tolerance 3) Internal failure	1) Check if electrical appliances in the vicinity are provided with the EMC-CZ certificate, eliminate any interference source 2) Measure line voltage - eliminate the cause 3) Restart the appliance, and contact the producer *										
The data on the display does not change, while the level in the measurement box is changing.	1) The monitoring probe evaluates improper reflection, for example, from wall, constructional elements, material deposits 2) Very thick foam layer on the surface	1) Check the correct probe bearing, free space below the sensor, remove deposit on walls 2) Locate the foam separator upstream the point being monitored.										
Display shows a correct level height in the full range, the reading of current flow is not real; if flow reduces below a certain minimum height, the sensor will indicate zero reading .	1) Incorrect conversion curve entered in the device, the measurement box does not comply with the assembly regulations 2) Incorrect parameter entered in the device menu	1) Check the conversion curve "Qa = f(Ha)" - (see pages 14 - 15 in the Manual), check the function and operation in the measurement point by an expert 2) Check the parameter "dH, Hsupp .." being entered - (see page 13 in the Manual), i.e. the standard setting for the boxes = 3 cm, for MPH = 0.5cm										
Display shows a constant difference of the monitored <u>level height</u> in the full range	1) Assembly distance of the probe from the bottom changed 2) Incorrect parameter entered in the device menu	1) Check the assembly distance from the measurement profile bottom, for example: the sensor <u>ASU 0.5 (0÷0.4)</u> has the assembly distance of 0.5 m from the bottom and the measurement range of 0÷0.4m 2) Verify the difference parameter "dH, Hsupp.." entered (see page 13 in the Manual).										
Error in level height measurement is remarkably increasing with an increasing distance from the resonator.	The atmosphere is not homogeneous	Set correctly the parameter "dH, Hsupp" (see page 13 in the Manual) at the lower level										
Reading fluctuates	Strong ripple of the surface monitored, liquid stirring below the sensor	Check the setting of the parameter "FILTER" (see page 13 in the Manual), typical setting: "Xa.filt = 0990; Xa.step = 0001"										
Reading is changing slowly	Level height is changing faster than the preset filtration constant	Check the parameter setting "FILTER" (see page 13 in the Manual), typical setting for faster operation: "Xa.filt=1990; Xa.step = 0011"										
Unstable flow and level height measurements	1) Electrical interference 2) Power supply failure at the sensor 3) Sensor/reader failure	1) Check, if the electrical appliances are provided with the EMC-CZ certificate, eliminate power supply source interference, use a shielded cable for the sensor - reader connection 2) Measure power supply voltage directly on the sensor (DC = 11÷15 V) 3) Restart the device, and contact the producer*										
Flow measurement will stop at the upper level of the open box range, reading is constant even for increasing flow	The level monitored reaches the "dead resonator area "	Relocate the sensor to the higher position above the bottom so that the "dead area" does not affect the level measured										
		<p><u>Minimum distances of the monitored levels:</u></p> <table border="1"> <thead> <tr> <th>Sensor</th> <th>Min. distance [ m ]</th> </tr> </thead> <tbody> <tr> <td>ASU 0.5</td> <td>0.1</td> </tr> <tr> <td>ASU 0.6 ÷ 2</td> <td>0.2</td> </tr> <tr> <td>ASU 4</td> <td>0.5</td> </tr> <tr> <td>ASU 6</td> <td>0.8</td> </tr> </tbody> </table>	Sensor	Min. distance [ m ]	ASU 0.5	0.1	ASU 0.6 ÷ 2	0.2	ASU 4	0.5	ASU 6	0.8
Sensor	Min. distance [ m ]											
ASU 0.5	0.1											
ASU 0.6 ÷ 2	0.2											
ASU 4	0.5											
ASU 6	0.8											



### \* CAUTION:

Troubleshooting in the electrical system can be performed only by a qualified person (see Regulations No. 50/1978 Coll. on The Qualification in Electrical Engineering).



## 8. Appendix

### 8.1.Warranty

The warranty conditions are covered by Arkon Flow Systems, s.r.o. Terms & Conditions of Sale and by Arkon Flow Systems, s.r.o Return Regulations and Warranty Conditions. The Arkon Flow Systems, s.r.o Terms & Conditions of Sale and the Arkon Flow Systems, s.r.o Return Regulations and Warranty Conditions are an integral part of the Resellers contract and of any Order Confirmation. Please see your Resellers contract or [www.arkon.co.uk](http://www.arkon.co.uk); Support section. The Warranty sheet is part of the Packing note of any new goods sent. For the claim or return procedure, please consult our web site [www.arkon.co.uk](http://www.arkon.co.uk) or call the Arkon Flow Systems, s.r.o sales office.

### 8.2.Contact



Technical support: [support@arkon.co.uk](mailto:support@arkon.co.uk)

Windows live messenger: [support@arkon.co.uk](mailto:support@arkon.co.uk)

Sales office: [office@arkon.co.uk](mailto:office@arkon.co.uk)

Office hours:

8:30 – 18:00 (GMT+1)

Direct technical support:

8:00 – 16:30 (GMT+1)